

SWE	MONTERINGSANVISNING NAUTIC
GBR	MOUNTING INSTRUCTIONS NAUTIC
DEN	MONTERINGSANVISNING NAUTIC
NOR	MONTERINGSANVISNING NAUTIC
FIN	NAUTIC YKSIOTEHANOJEN ASENNUSOHJE
EST	NAUTIC PAIGALDUSJUHEND
LAT	UZSTĀDĪŠANAS INSTRUKCIJA NAUTIC
LTU	NAUTIC MONTAVIMO INSTRUKCIJA
UKR	ІНСТРУКЦІЯ З МОНТАЖУ NAUTIC
CZE	MONTÁŽNÍ NÁVOD NAUTIC BATERIE
SVK	MONTÁŽNY NÁVOD NAUTIC BATÉRIE
ROU	INSTRUCȚIUNI DE MONTARE NAUTIC

GUSTAVSBERG /
SMARTER BATHROOMS

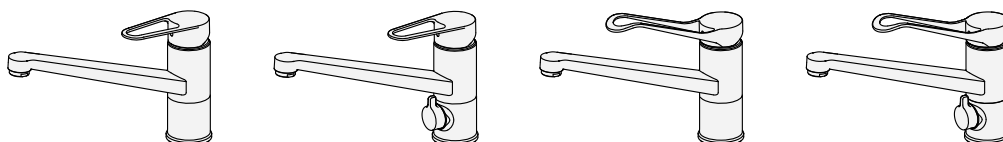

Accepterad
monteringsanvisning
2021:1

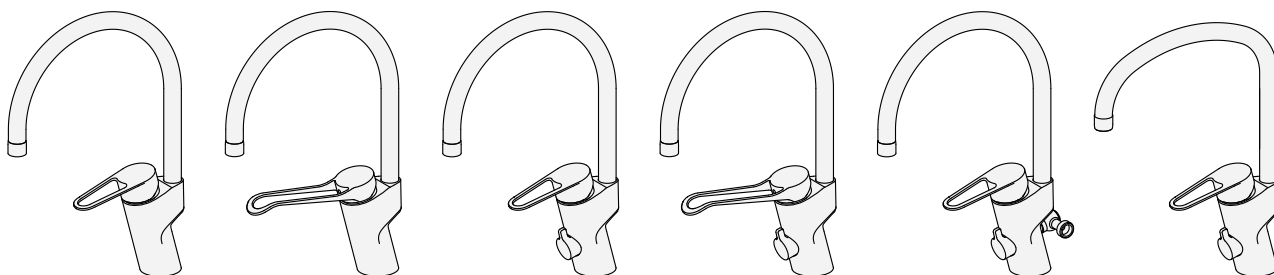
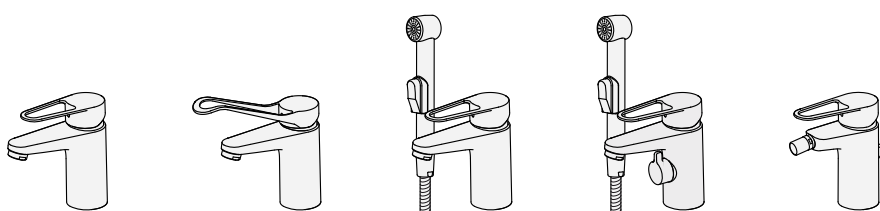

Garanti. Takuu. Guarantee. Garantii. Garantija.
Garantija. Гарантія. Zárúki. Garanție. Гарантія.

3



Tekniska data
Technical data.

4-6



Varningar
Warnings

7



Nautic



8-9



Nautic

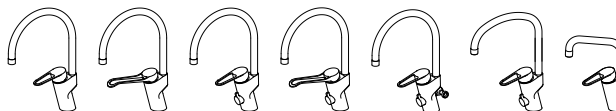

10-11



11



Nautic



12

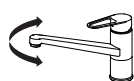

13

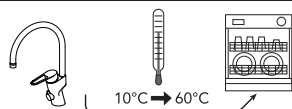

14



Begränsa maxflödet
Limit maximum flow
Begrænse det maksimale flow
Begrænse den maksimale gennemstrømningen
Rajoita maksimivirtaus
Ограничение максимального потока воды

Vooluhulga seadistamine
Maksimālā ūdens plūsmā
Maksimāli vandens srovē
Обмеження максимального потоку

15



Begränsa temperaturen
Limit temperature
Begrænse temperaturen
Begrænse temperaturen
Kuuman veden rajoittaminen
Настройка ограничителя температуры

Temperatuuri piiramine
Temperatūras ierobežošana
Ribota temperatūra
Лімітування температури
Hraniční teplota
Hraničná teplota

15



Skötsel
Maintenance
Beskyttelse
Vedlikehold
Hoito-ohje
Уход

Hooldus
Kopšanas informācija
Montavimas
Догляд
Péče o baterii
Starostlivosť o batériu

16



Rengöring
Clean
Rengøring
Rengjøring
Puhdistus
очистка

Puhastamine
Tīrīšana
Švarus
Очищення
Čistý

16

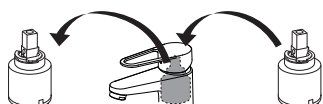

17



18



Reservdelar
Reservevedeler
Reservevedele
Varaosat
Spare parts

Varuosad
Atsarginės dalys
Rezerves Daļas
ЗАПАСНЫЕ ЧАСТИ

19

SE GARANTI

Produkten har garanti enligt respektive lands gällande branschvillkor.

Direktiv vid reklamation

Våra produkter är tillverkade enligt väldigt stränga kvalitetskrav. Om en produkt trots det är felaktig, ber vi er i första hand att kontakta din återförsäljare. Ärendet underlättas genom att uppvisa kvitto och uppge produktnummer och inköpsdatum.

DK GARANTI

Produktet har garanti i forhold til gældende dansk lovgivning.

Vejledning ved reklamation

Vores produkter er fremstillet i overensstemmelse med markedets strengeste krav til kvalitet. Skulle produktet mod forventning være behæftet med fejl henviser vi til den forhandler, hvor produktet er købt. Kvittering skal kunne fremvises, hvis forhandleren forlanger det, ligesom oplysninger om produktnummer og købsdato skal kunne dokumenteres.

NO GARANTI

Produktene har garanti i henhold til respektive lands gjeldende bransjevilkår.

Instrukser ved reklamasjon

Våre produkter er produsert i henhold til veldig strenge kvalitetskrav. Om et produkt til tross for dette skulle være feilaktig, ber vi deg vennligst ta kontakt med forhandleren. Vi ber deg medbringe kvittering og oppgi innkjøpsdato samt produktnummer.

FI TAKUU

Noudatamme alamme yleisiä toimitusehtoja.

Reklamaatio

Tuotteemme ovat valmistettu Villeroy & Bochin ja Gustavsbergin laatuvaatimuksien mukaisesti. Mikäli tuote kuitenkin on virheellinen pyydämme teitä kääntymään ensisijaisesti tuotteen myyjän puoleen. Käsitelyn helpottamiseksi säilyttäkää tosite tuotteen ostosta.

GB GUARANTEE

The product has a guarantee accordingly to industry rules in every country.

Instructions for complaints

Our products are made according to very strict quality demands. If the product is faulty in spite of that we ask you kindly to take it to your retailer. We also ask you to bring the receipt and be prepared to inform about the product number and purchasing date.

EE GARANTII

Antud tootel on garantii vastavalt tehase poolt kehtestatud tingimustele.

Juhised reklamatsioonide käsitlemiseks

Meie tooted on valmistatud silmas pidades väga täpseid kvaliteedistandardeid. Juhul kui olete saanud praaktoote, palume Teil toimetada see kas meie edasimüüja juurde või võtta ühendust esindusega. Samuti palume alles hoida ostutšekk ning vajadusel anda informatsiooni tootenumbri ja ostu sooritamise aja kohta.

LV GARANTIJA

Izstrādājumam ir garantija saskaņā ar ražotāja standartiem.

Instrukcija kvalitātes problēmu gadījumā

Mūsu produkcija tiek ražota pēc ļoti striktiem kvalitātes kritērijiem. Taču – gadījumā, ja produktam tiek konstatēta kvalitātes problēma – lūdzam sazināties ar pārdevēju. Lūdzam, esiet gatavi arī uzrādīt pirkuma čeku ar pirkuma datumu.

LT GARANTIJA

Gaminiams garantija suteikiama atsizvelgiant į konkrečios šalies kokybės reikalavimus.

Reklamacijos

Mūsų produkcija pagaminta vadovaujantis griežtais kokybės reikalavimais. Jei gaminys nekokybiškas – prašome jį grąžinti pardavėjui, pateikiant pirkimo čekį, gaminio numerį bei nurodant pirkimo datą.

ГАРАНТІЯ

Ця продукція підтримується гарантією у відповідності з правилами та законами, що діють у країні збуту.

Рекламації

Наша продукція відповідає сучасним стандартам та вимогам щодо якості. У випадку виникнення несправності, Ви можете звернутися в торгову організацію, де був придбаний цей виріб. Для оформлення рекламації необхідно додати супровідні документи щодо виробу та чек, що підтверджує найменування та дату покупки

RU ГАРАНТИЯ

Гарантийные условия устанавливаются в соответствии с законами и правилами, которые действуют в стране сбыта.

Рассмотрение рекламаций

Наша продукция соответствует современным стандартам и требованиям к качеству. В случае возникновения неисправности Вы можете обратиться в торговую организацию, где было приобретено данное изделие. При заявлении рекламации необходимо предъявить сопроводительные документы к данной продукции и чек, подтверждающий дату покупки.

GARANTII

Antud tootele kehtivad garantiitingimused tulenevad kohalikest õigusaktidest.

Juhised reklamatsioonide käsitlemiseks

Meie tooted on valmistatud silmas pidades väga täpseid kvaliteedistandardeid. Juhul kui olete saanud praaktoote, palume Teil toimetada see kas meie edasimüüja juurde või võtta ühendust esindusega. Samuti palume alles hoida ostutšekk ning vajadusel anda informatsiooni tootenumbri ja ostu sooritamise aja kohta.

GARANTIJA

Produktam ir garantija atbilstoši nozares noteikumiem konkrētajā valstī.

nstrukcijas sūdzību pieteikšanai

Mūsu produkti ir izgatavoti saskaņā ar ļoti stingriem kvalitātes prasībām. Tomēr, ja produkts ir bojāts, mēs lūdzam griezties produkta iegādes vietā. Mēs lūdzam arī sagatavot uzrādīšanai pirkuma čeku un informāciju par pirkuma datumu.



GARANTIJA

Gaminiams garantija suteikiama atsizvelgiant į konkrečios šalies kokybes reikalavimus.

Pretenzijos

Mūsų produkcija pagaminta vadovaujantis griežtais kokybes reikalavimais. Jei gaminys nekokybiškas – prašome jį grąžinti pardavėjui, pateikiant pirkimo čekį, bei nurodyti pirkimo datą

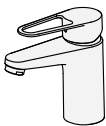
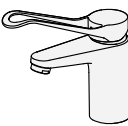
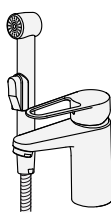
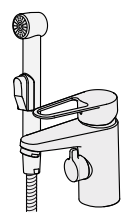
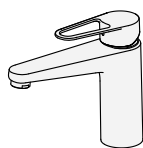
TEKNISK DATA / TECHNICAL DATA

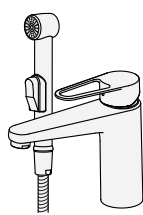
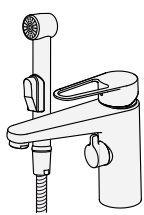
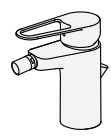
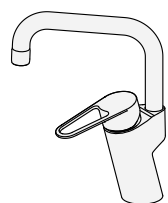
	<table border="1"> <thead> <tr> <th>Art nr/Art No</th> <th>RSK No</th> </tr> </thead> <tbody> <tr> <td>GB412160470</td> <td>8278510</td> </tr> <tr> <td>GB41216047</td> <td>8278500</td> </tr> <tr> <td>GB41216047R</td> <td>8278503</td> </tr> <tr> <td>GB41216051</td> <td>8278499</td> </tr> <tr> <td>GB41216051R</td> <td>8278502</td> </tr> <tr> <td>GB41216043</td> <td>8278501</td> </tr> <tr> <td>GB41216047060</td> <td>8278505</td> </tr> <tr> <td>GB4121604760</td> <td>8278504</td> </tr> </tbody> </table>	Art nr/Art No	RSK No	GB412160470	8278510	GB41216047	8278500	GB41216047R	8278503	GB41216051	8278499	GB41216051R	8278502	GB41216043	8278501	GB41216047060	8278505	GB4121604760	8278504		<table border="1"> <thead> <tr> <th>Art nr/Art No</th> <th>RSK No</th> </tr> </thead> <tbody> <tr> <td>GB41216047064</td> <td>8278509</td> </tr> </tbody> </table>	Art nr/Art No	RSK No	GB41216047064	8278509
Art nr/Art No	RSK No																								
GB412160470	8278510																								
GB41216047	8278500																								
GB41216047R	8278503																								
GB41216051	8278499																								
GB41216051R	8278502																								
GB41216043	8278501																								
GB41216047060	8278505																								
GB4121604760	8278504																								
Art nr/Art No	RSK No																								
GB41216047064	8278509																								
	<table border="1"> <thead> <tr> <th>Art nr/Art No</th> <th>RSK No</th> </tr> </thead> <tbody> <tr> <td>GB412161470</td> <td>8278508</td> </tr> <tr> <td>GB41216147</td> <td>8278507</td> </tr> <tr> <td>GB41216151</td> <td>8278506</td> </tr> </tbody> </table>	Art nr/Art No	RSK No	GB412161470	8278508	GB41216147	8278507	GB41216151	8278506		<table border="1"> <thead> <tr> <th>Art nr/Art No</th> <th>RSK No</th> </tr> </thead> <tbody> <tr> <td>GB41216187</td> <td>8278497</td> </tr> </tbody> </table>	Art nr/Art No	RSK No	GB41216187	8278497										
Art nr/Art No	RSK No																								
GB412161470	8278508																								
GB41216147	8278507																								
GB41216151	8278506																								
Art nr/Art No	RSK No																								
GB41216187	8278497																								
	<table border="1"> <thead> <tr> <th>Art nr/Art No</th> <th>RSK No</th> </tr> </thead> <tbody> <tr> <td>GB412160450</td> <td>8278516</td> </tr> <tr> <td>GB41216045</td> <td>8278511</td> </tr> <tr> <td>GB41216045R</td> <td>8278512</td> </tr> </tbody> </table>	Art nr/Art No	RSK No	GB412160450	8278516	GB41216045	8278511	GB41216045R	8278512		<table border="1"> <thead> <tr> <th>Art nr/Art No</th> <th>RSK No</th> </tr> </thead> <tbody> <tr> <td>GB41216045064</td> <td>8278515</td> </tr> </tbody> </table>	Art nr/Art No	RSK No	GB41216045064	8278515										
Art nr/Art No	RSK No																								
GB412160450	8278516																								
GB41216045	8278511																								
GB41216045R	8278512																								
Art nr/Art No	RSK No																								
GB41216045064	8278515																								
	<table border="1"> <thead> <tr> <th>Art nr/Art No</th> <th>RSK No</th> </tr> </thead> <tbody> <tr> <td>GB412161450</td> <td>8278514</td> </tr> <tr> <td>GB41216145</td> <td>8278513</td> </tr> </tbody> </table>	Art nr/Art No	RSK No	GB412161450	8278514	GB41216145	8278513		<table border="1"> <thead> <tr> <th>Art nr/Art No</th> <th>RSK No</th> </tr> </thead> <tbody> <tr> <td>GB41216185</td> <td>8278498</td> </tr> </tbody> </table>	Art nr/Art No	RSK No	GB41216185	8278498												
Art nr/Art No	RSK No																								
GB412161450	8278514																								
GB41216145	8278513																								
Art nr/Art No	RSK No																								
GB41216185	8278498																								
	<table border="1"> <thead> <tr> <th>Art nr/Art No</th> <th>RSK No</th> </tr> </thead> <tbody> <tr> <td>GB41216071</td> <td>8262611</td> </tr> </tbody> </table>	Art nr/Art No	RSK No	GB41216071	8262611		<table border="1"> <thead> <tr> <th>Art nr/Art No</th> <th>RSK No</th> </tr> </thead> <tbody> <tr> <td>GB41216251</td> <td>8246915</td> </tr> </tbody> </table>	Art nr/Art No	RSK No	GB41216251	8246915														
Art nr/Art No	RSK No																								
GB41216071	8262611																								
Art nr/Art No	RSK No																								
GB41216251	8246915																								

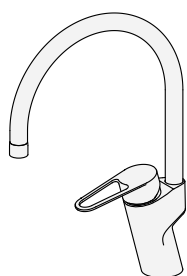

Art nr/Art No	RSK No
GB412060560	8311472
GB41206056	8311481
GB41206056R	8311483
GB41206058	8311459
GB41206058R	8311463

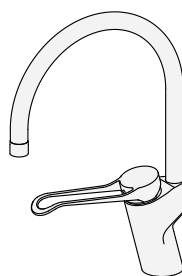

Art nr/Art No	RSK No
GB41206056064	8311471

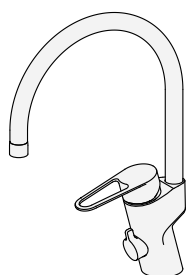

Art nr/Art No	RSK No
GB412060960	8311468
GB41206096	8311462
GB41206096R	8311466
GB41206098	8311460
GB41206098R	8311464
GB4120609632	8311469

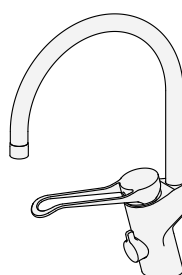

Art nr/Art No	RSK No
GB41206096064	8311467

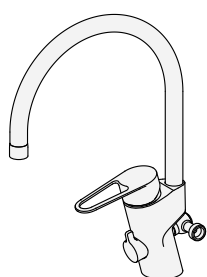

Art nr/Art No	RSK No
GB412060966	8311470



Art nr/Art No	RSK No
GB41206097	8311461
GB41206097R	8311465

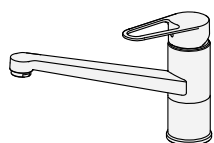

Art nr/Art No	RSK No
GB412060550	8311480
GB41206055	8311475
GB41206055R	8311476

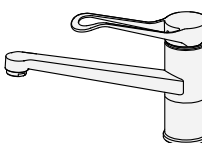

Art nr/Art No	RSK No
GB41206055064	8311479

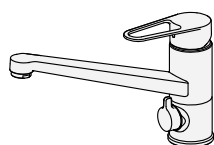

Art nr/Art No	RSK No
GB412060950	8311478
GB41206095	8311473
GB41206095R	8311474

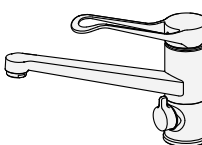

Art nr/Art No	RSK No
GB41206095064	8311477

TEKNISK DATA / TECHNICAL DATA



SC0303-19, SC0304-19



SV: Dessa blandare uppfyller kraven gällande återströmning enligt SS-EN 1717 och SäVa § 4.3.2 utan behov av kompletterande produkter eller åtgärder.

Standard / Standard	EN 817
Drifttryck / Working pressure	50-1000 kPa
Provningstryck max / Testpressure max	1600 kPa
Max varmvattentemperatur / Max. hot water temperature	70° C
Rekommenderad varmvattentemp. / Recommended hot water temp.	60° C
Kallvattentemperatur / Cold water	10° C
Anslutning / Connection	Soft Pex®
För slätända Ø10 mm behövs ingen stödhylsa / Connection pipe Ø10 mm have no need for extra tube support. G3/8 lekande mutter med inkluderad packning, ansluts mot slät ända/ G3/8 swiveling nut with gasket included.	
Återströmningsskydd / Backflow preventer	AA
Ejektorfunktion och handdusch med automatisk avstängning enligt SäVa § 4.3.2 Backflow preventer side spray: Ejector and Self closing handle	
Desinfektion / Thermal disinfection	70° C. 4 minutes

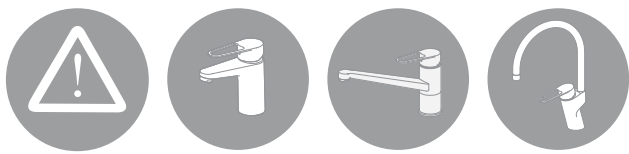

NAUTIC

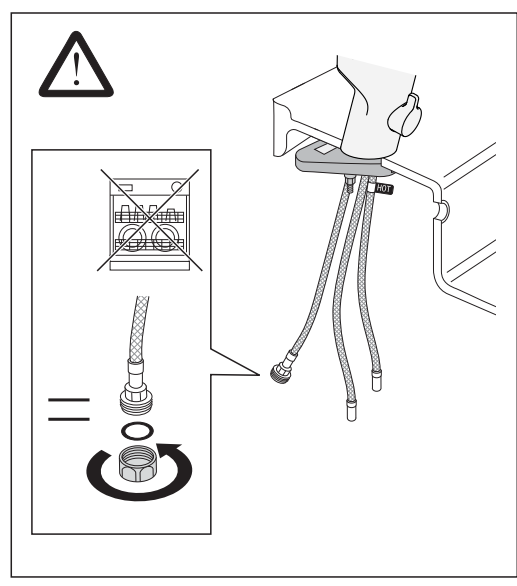
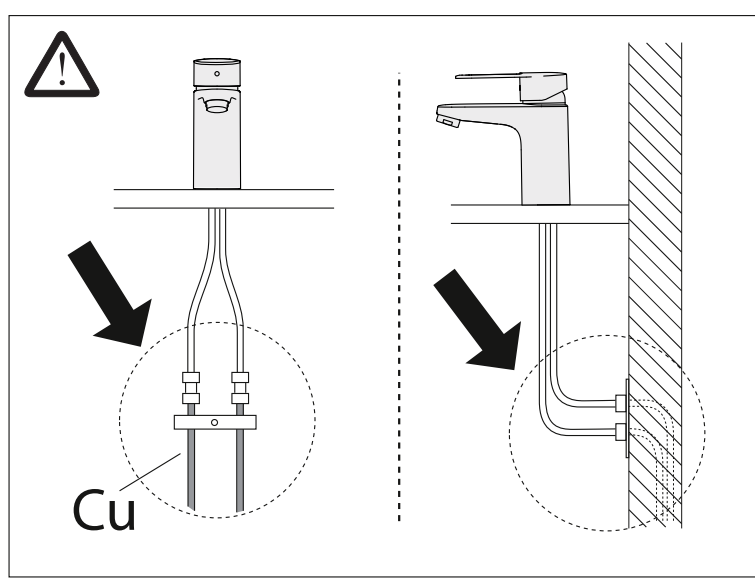
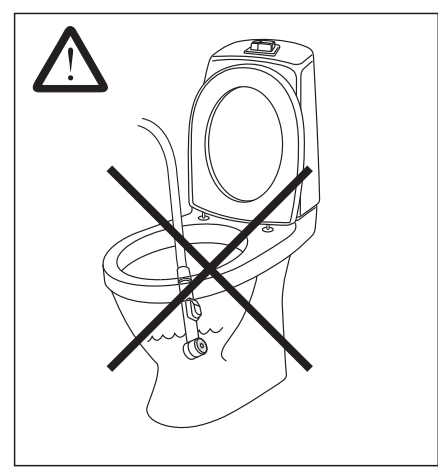
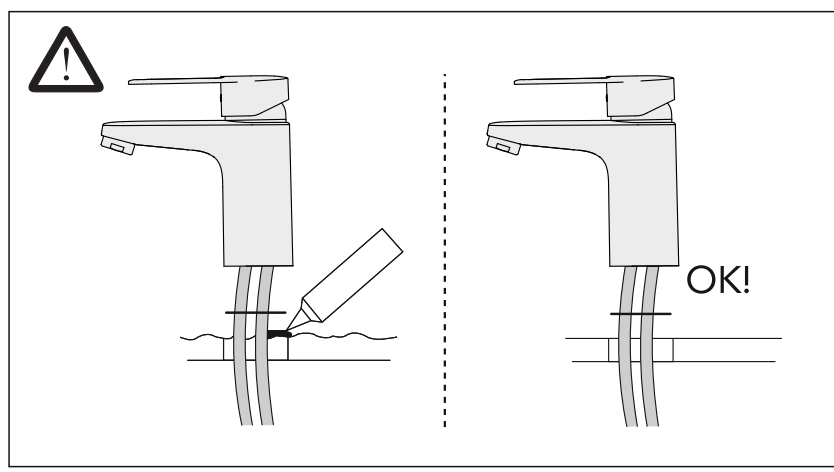
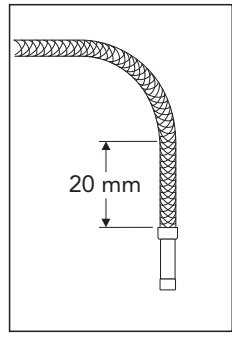
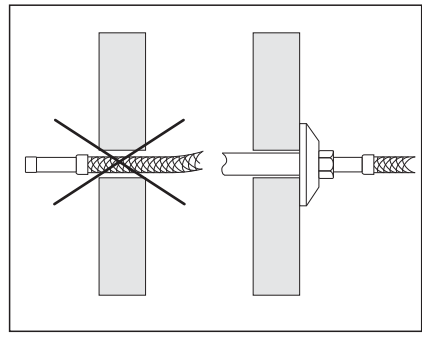
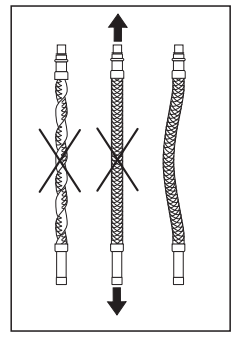
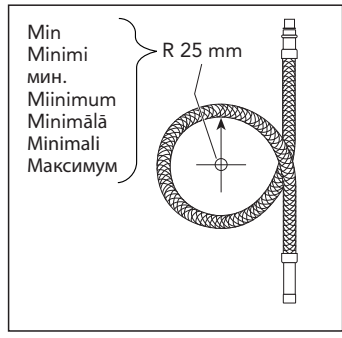

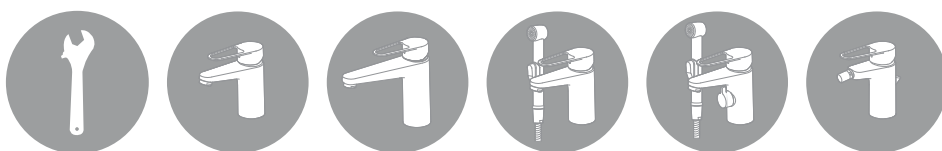

NAUTIC

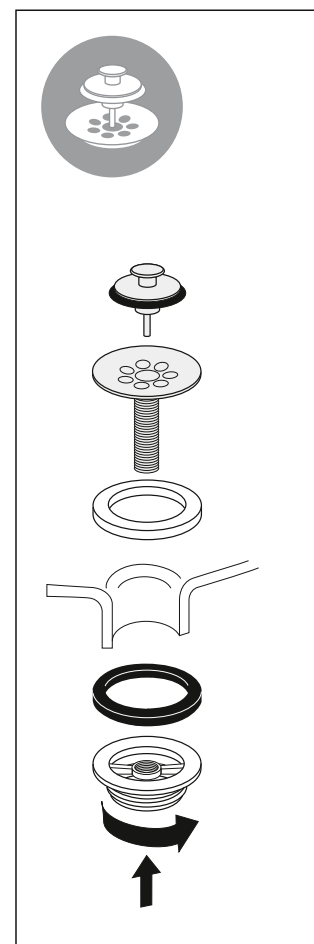
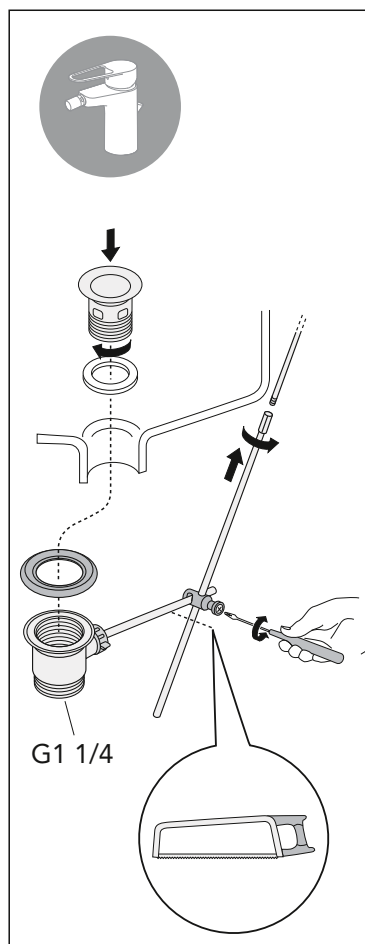
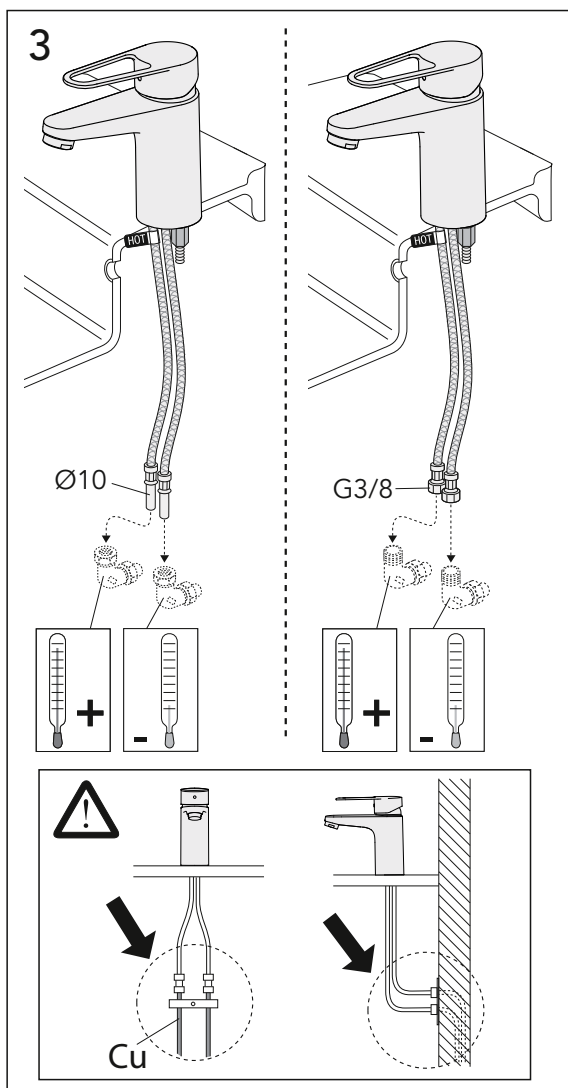
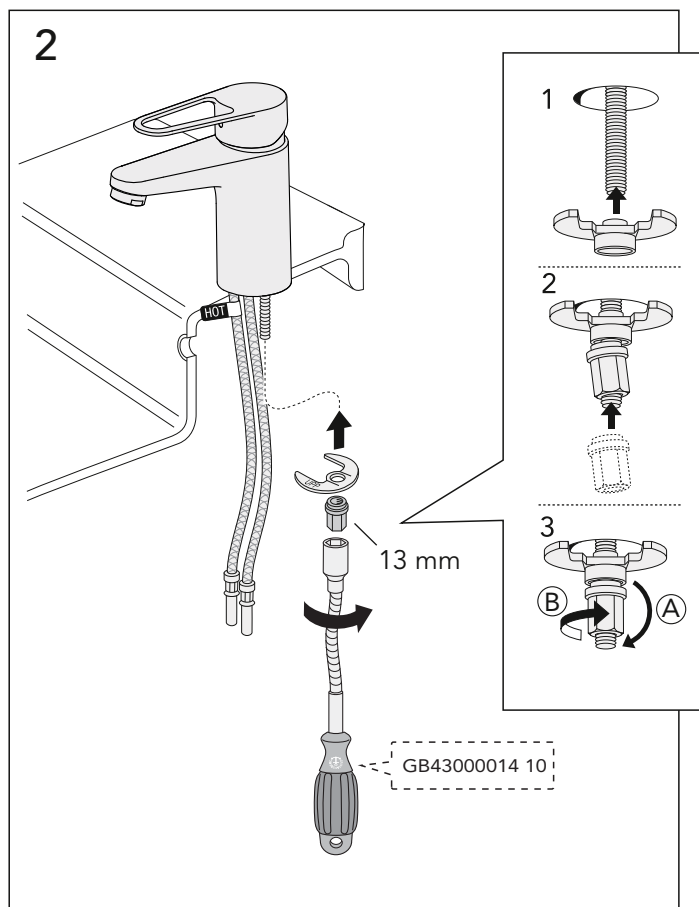
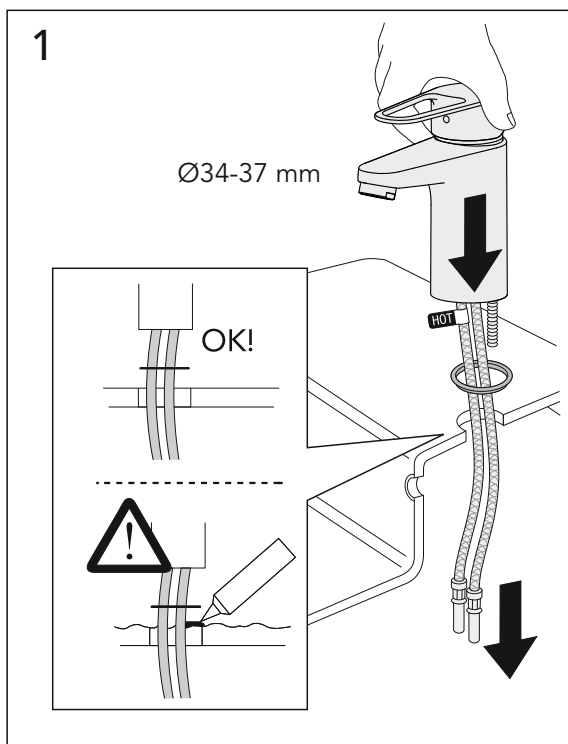



NAUTIC

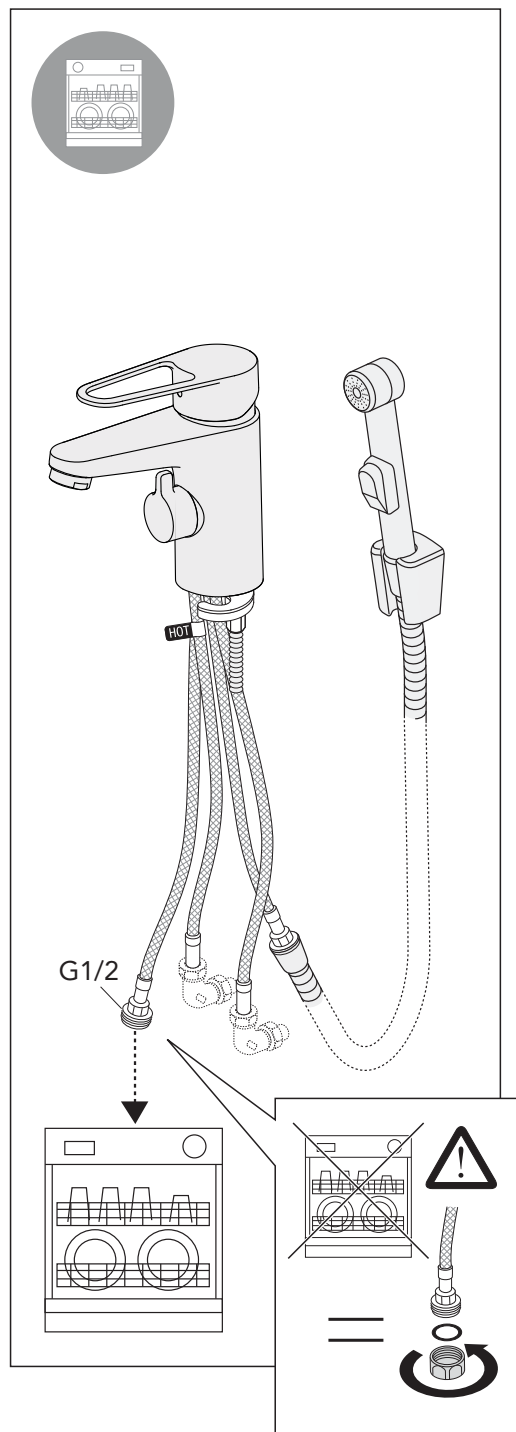
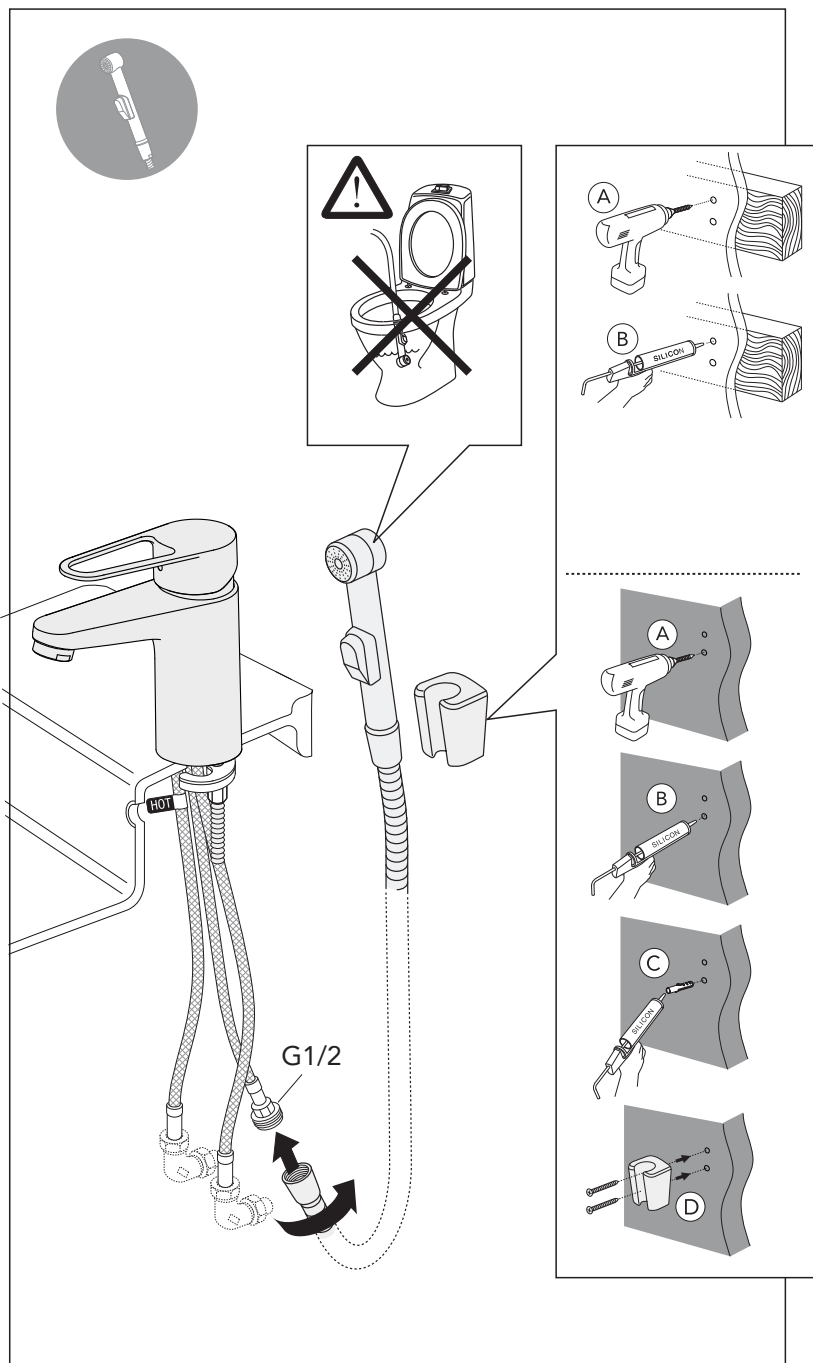

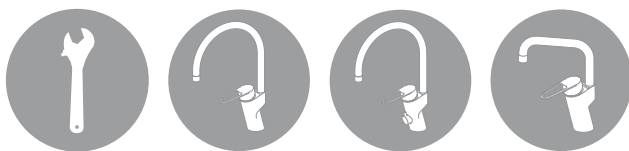

NAUTIC

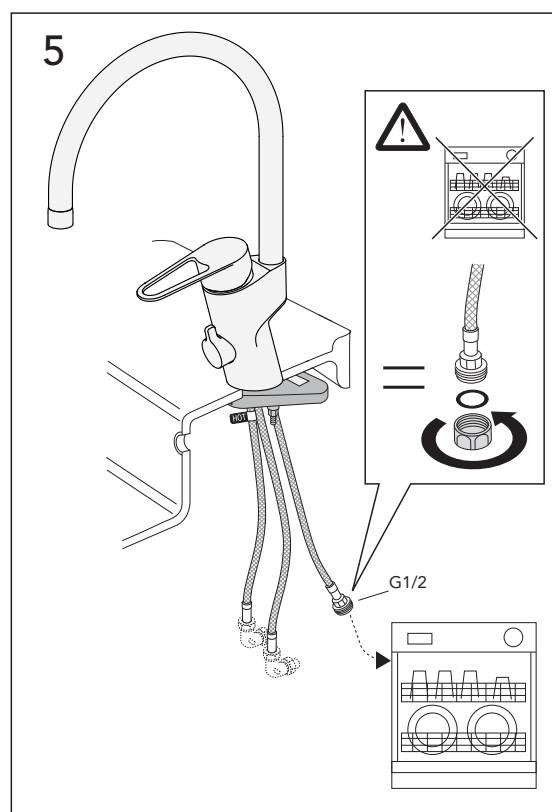
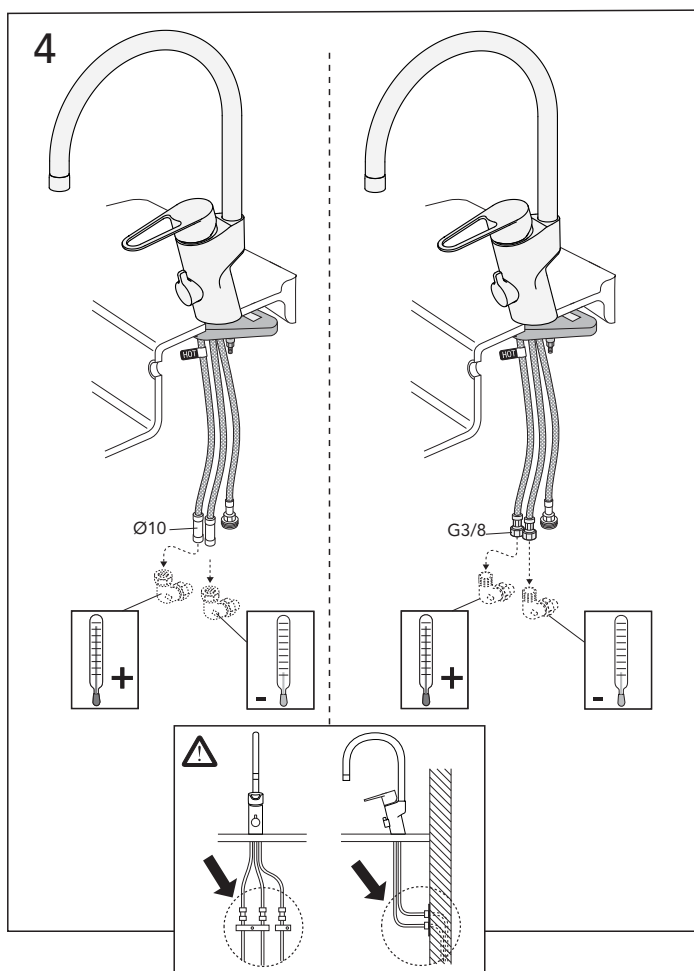
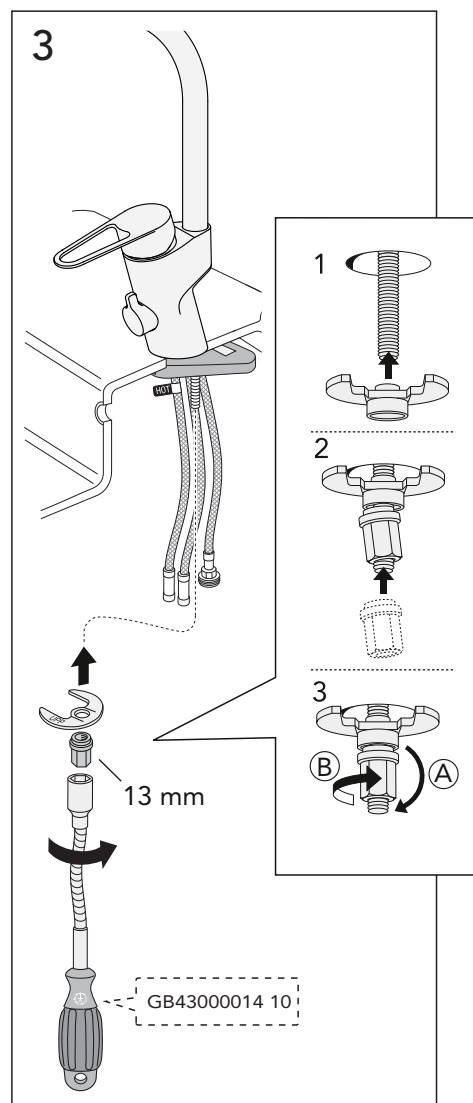
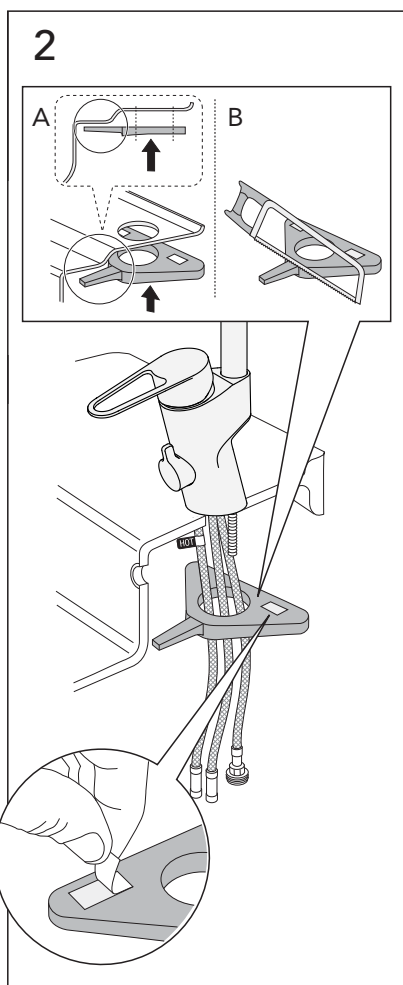
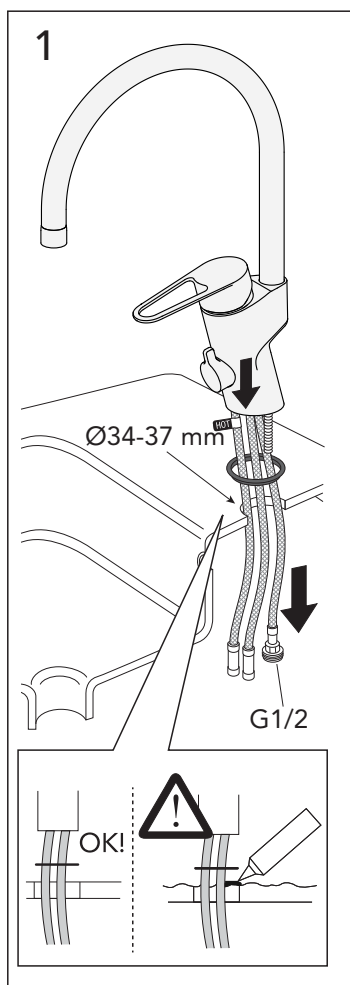



NAUTIC

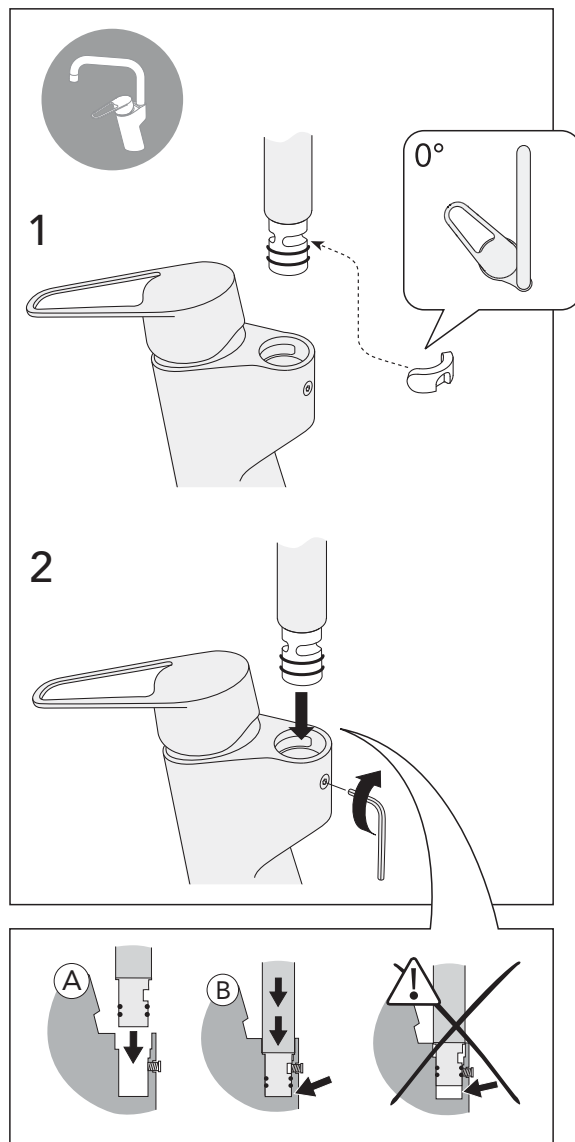
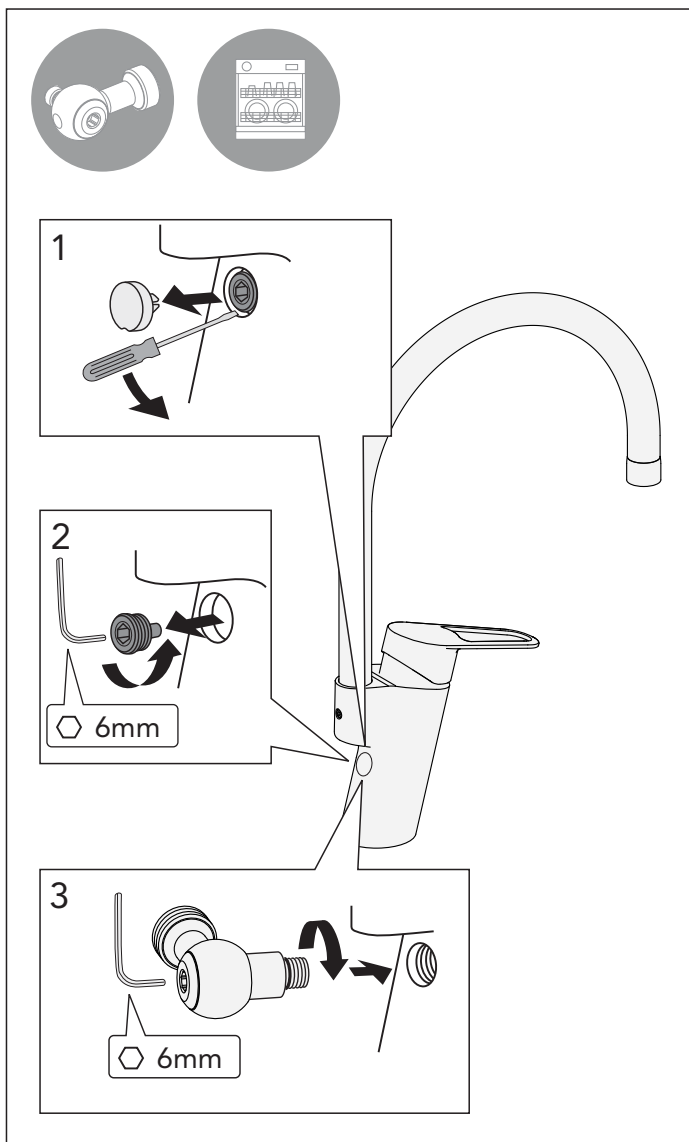

NAUTIC

Pip
Spout
Tud
Tut

Juoksuputki
излив
Jooksutoru
Snipsis

Snapas
Вилив
Üstí
Üstie

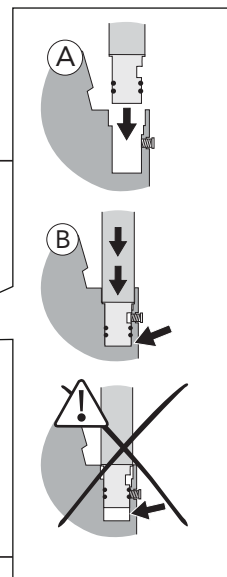
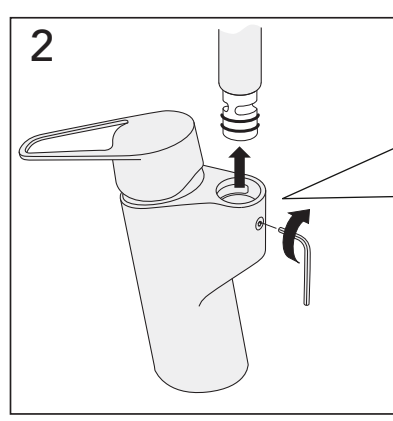
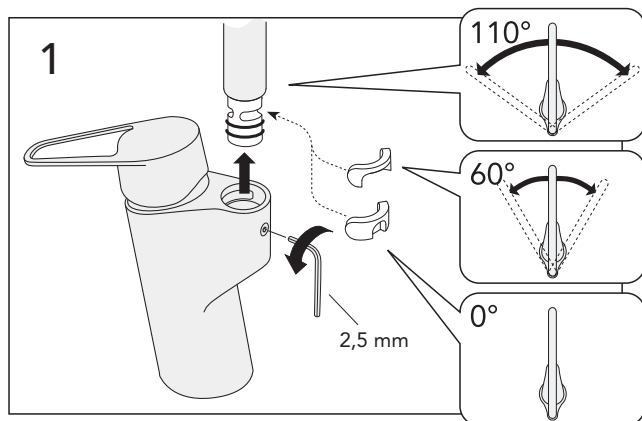



NAUTIC

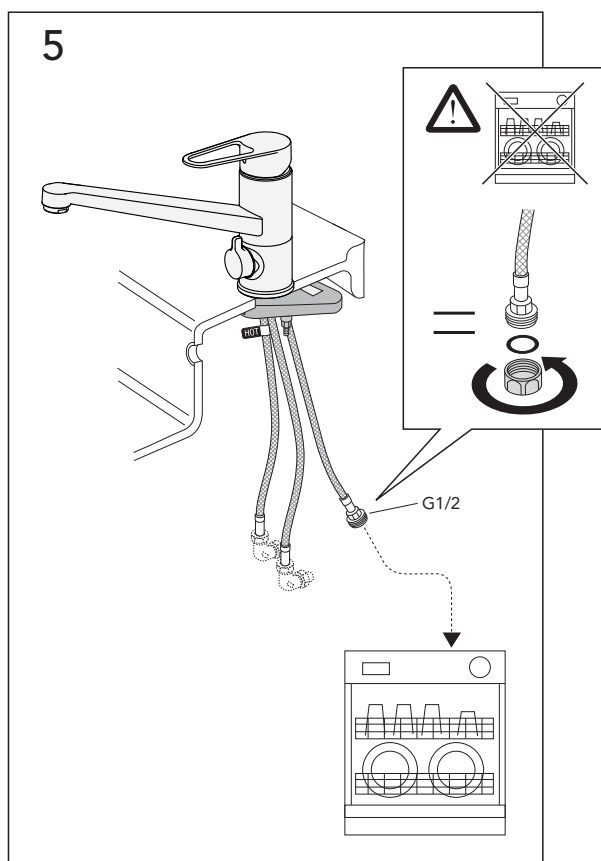
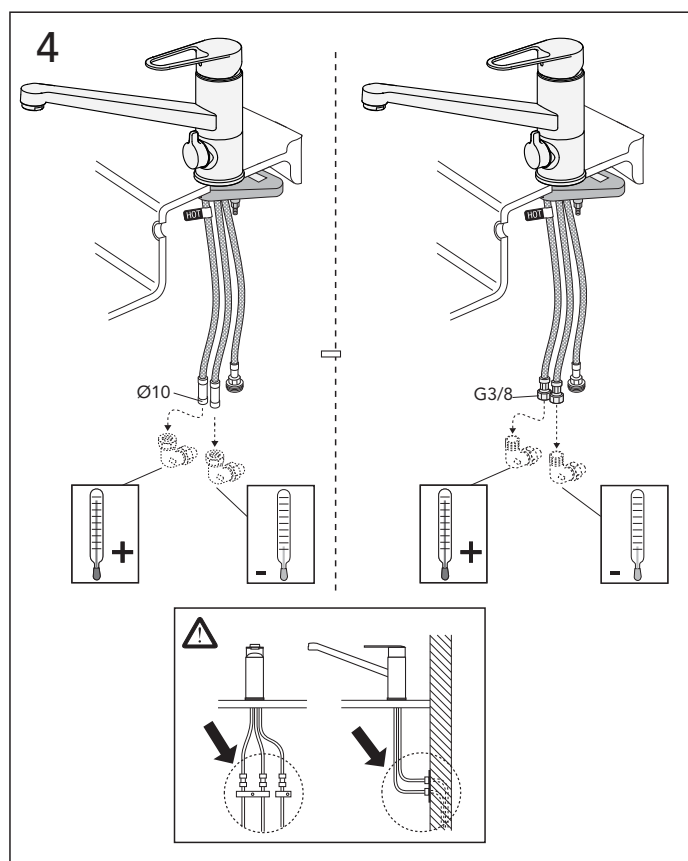
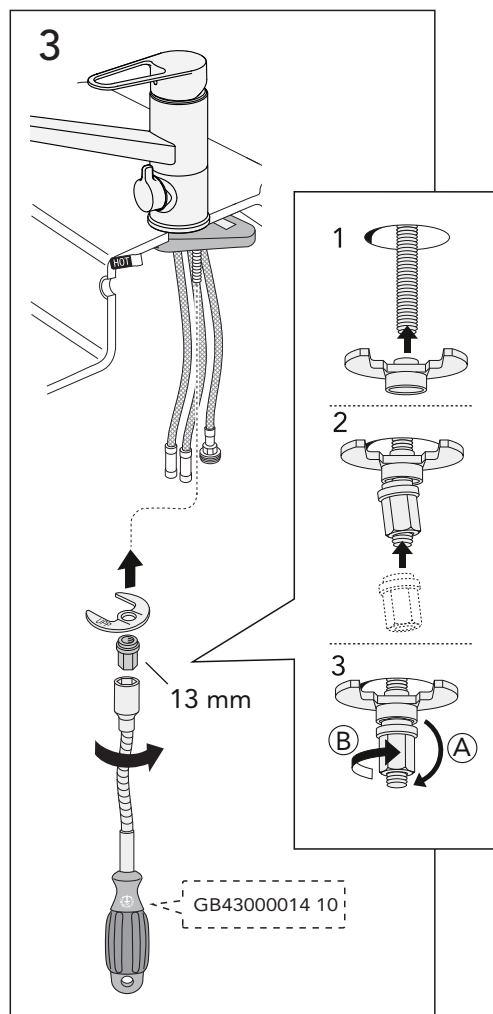
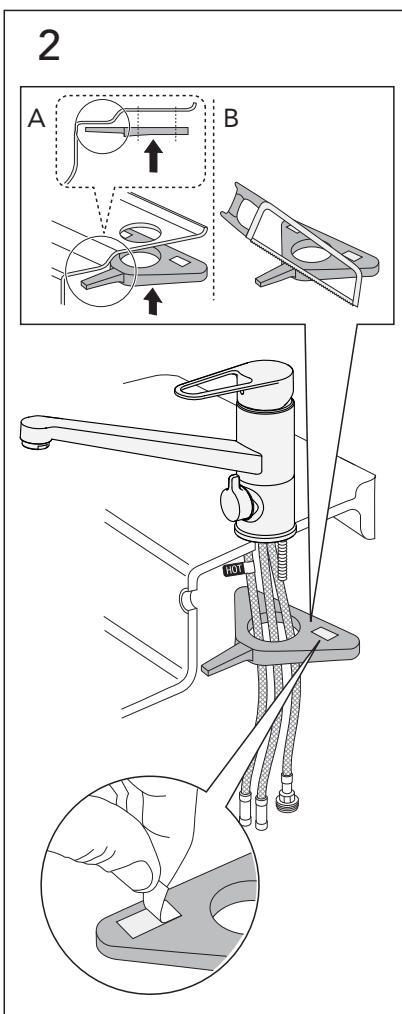
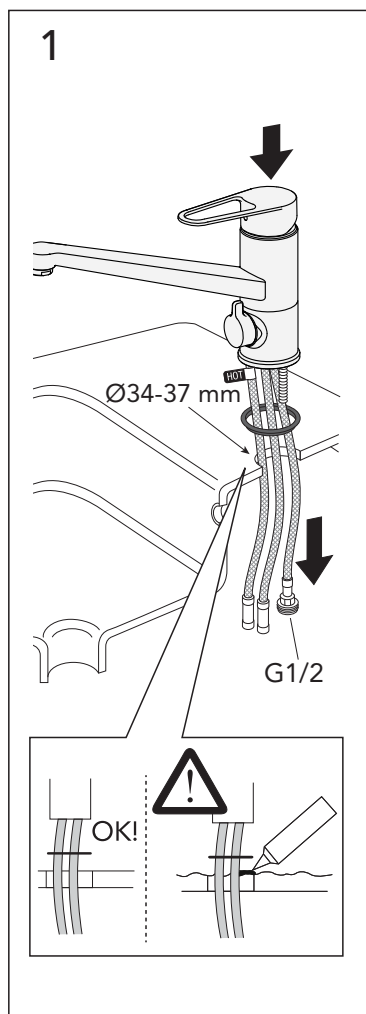



NAUTIC

Pip
Spout
Tud
Tut

Juoksuputki
излив
Jooksutoru
Snipsis

Snapas
Вилив
Ūstī
Ūstie

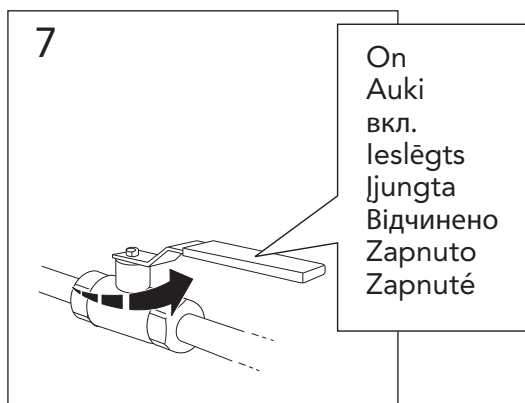
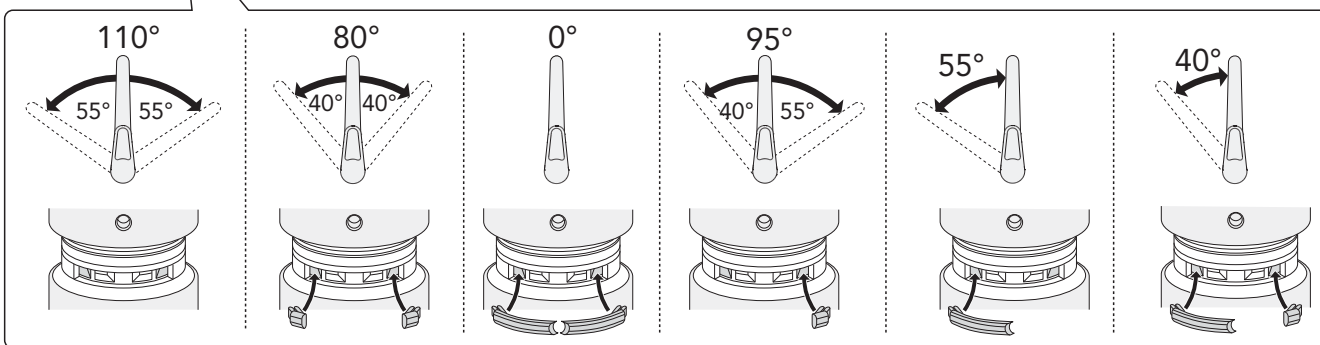
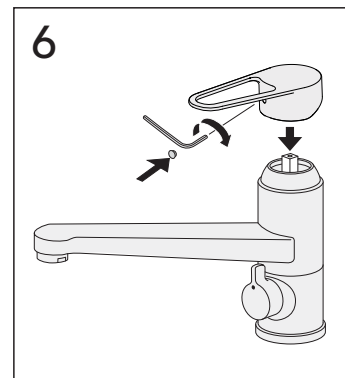
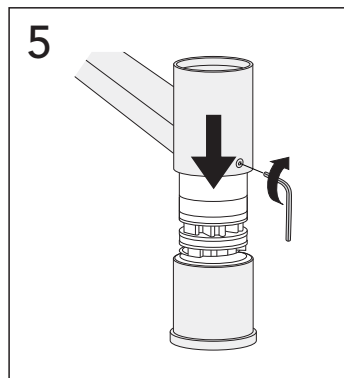
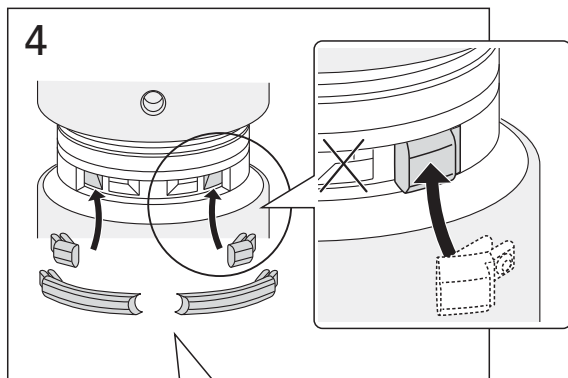
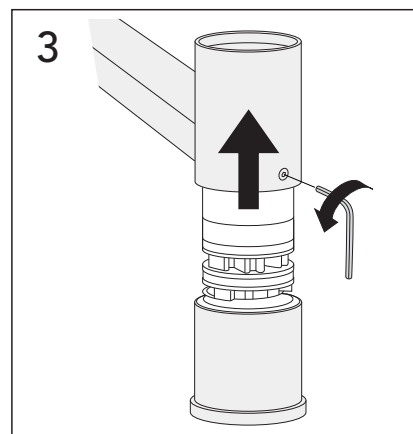
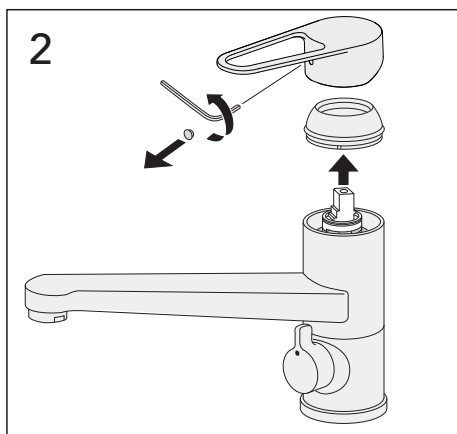
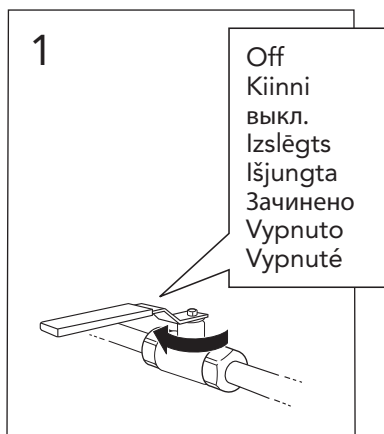

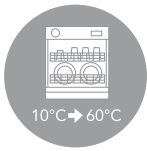

NAUTIC

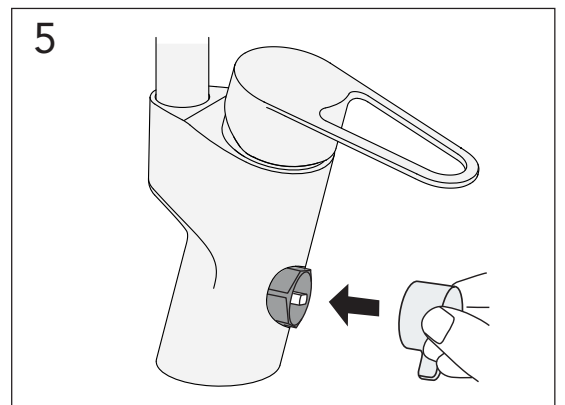
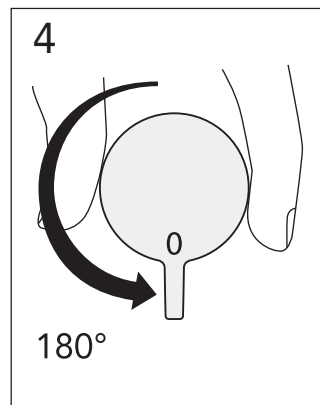
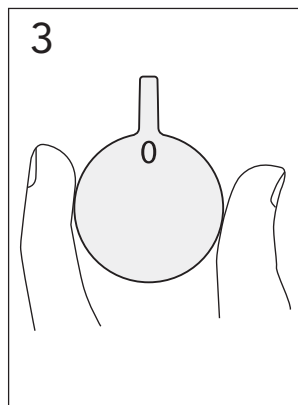
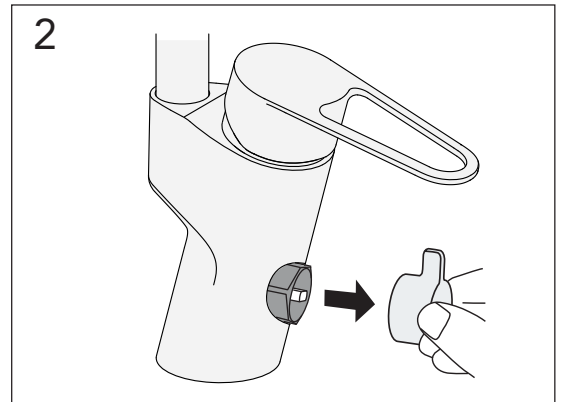
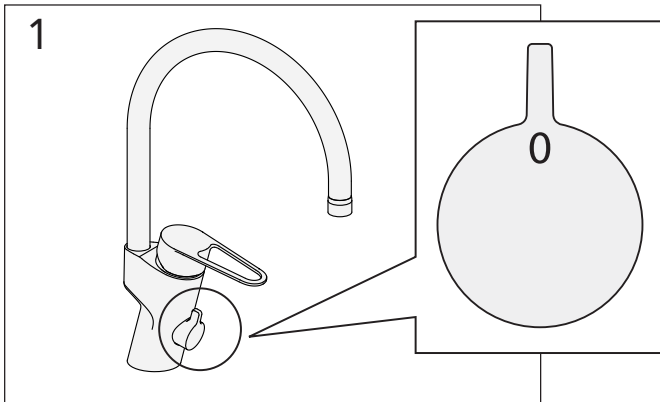
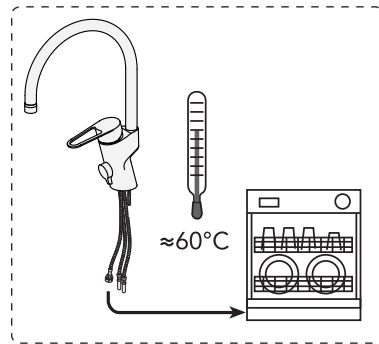
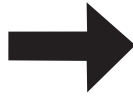
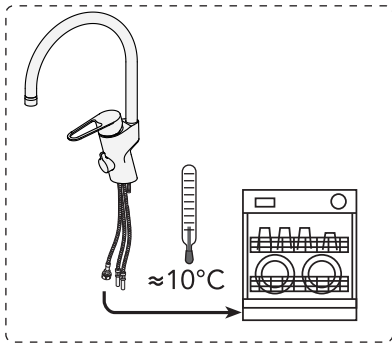



NAUTIC

Begränsa maxflödet
 Limit maximum flow
 Begrænse det maksimale flow
 Begrense den maksimale gennemstrømningen
 Rajoita maksimivirtaus
 Ограничение максимального потока воды

Vooluhulga seadistamine
 Maksimālā ūdens plūsma
 Maksimāli vandens srovē
 Обмеження максимального потоку

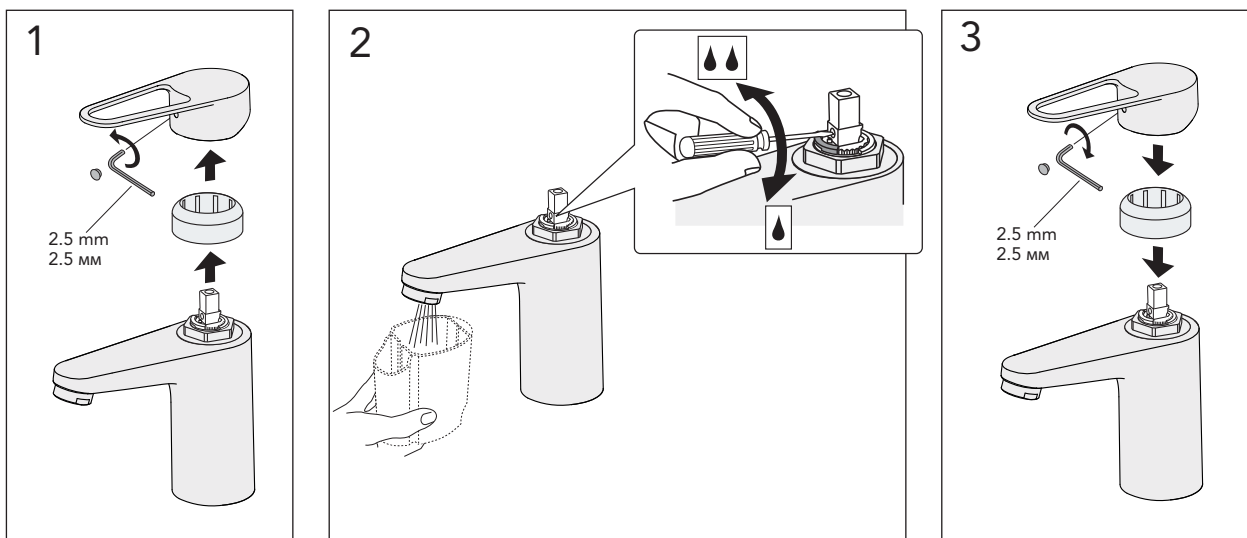

NAUTIC

Begränsa temperaturen
 Limit temperature
 Begrænse temperaturen
 Begrense temperaturen
 Kuuman veden rajoittaminen
 Настройка ограничителя температуры

Temperatuuri piiramine
 Temperatūras ierobežošana
 Ribota temperatūra
 Лімітування температури
 Hraníční teplota
 Hraníčná teplota

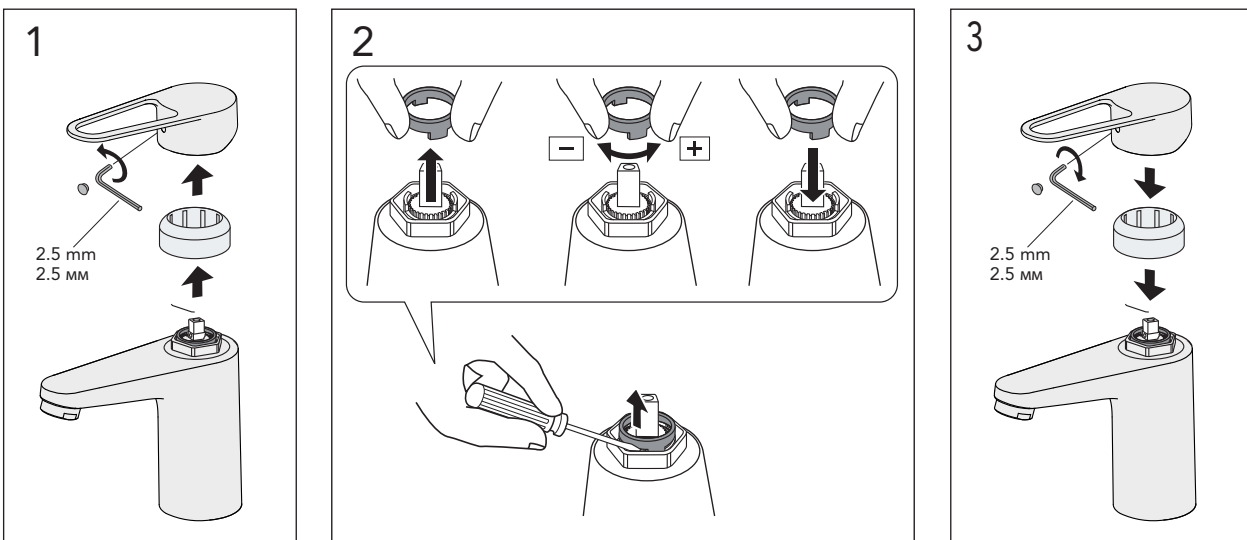

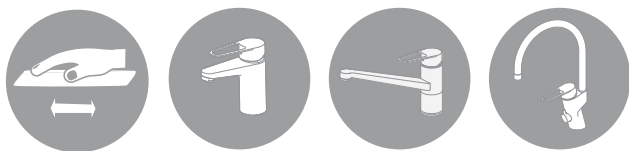

NAUTIC

Skötsel
Maintenance
Beskyttelse
Vedlikehold
Hoito-ohje
Уход
Hooldus
Koršanas informācija
Montavimas
Догляд
Péče o baterii
Starostlivosť o batériu

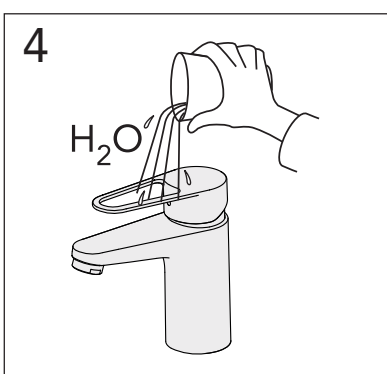
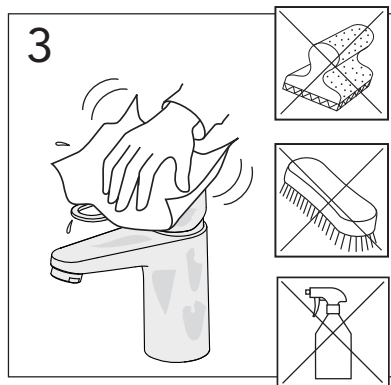
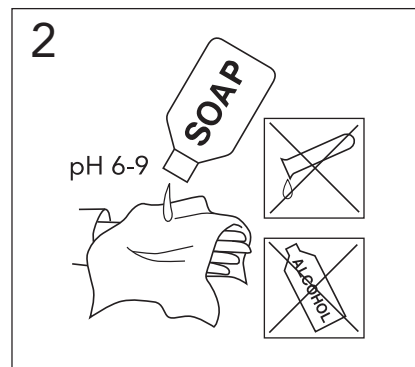
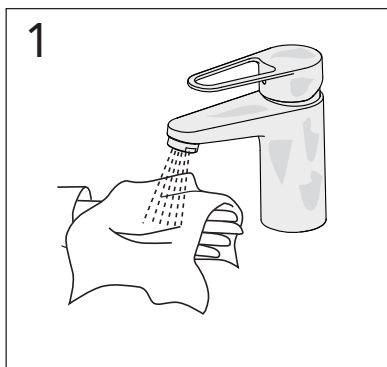

NAUTIC

Rengöring
Clean
Rengøring
Rengjöring
Puhdistus
очистка
Puhastamine
Tīrīšana
Švarus
Очищення
Čistý

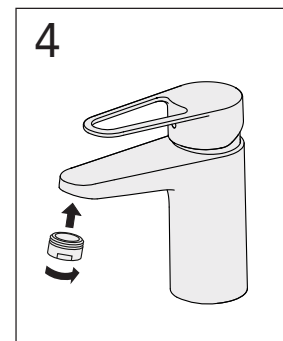
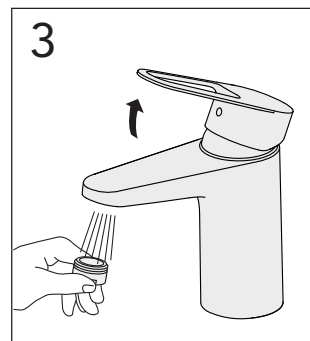
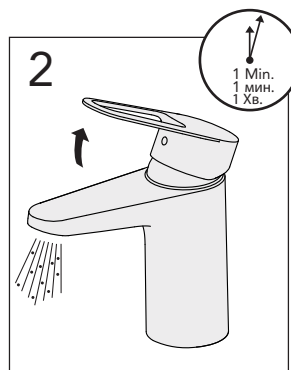
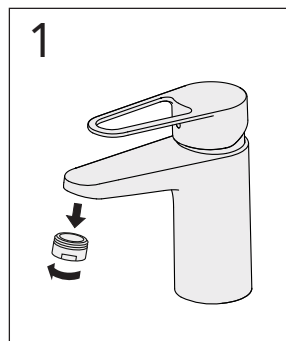



NAUTIC

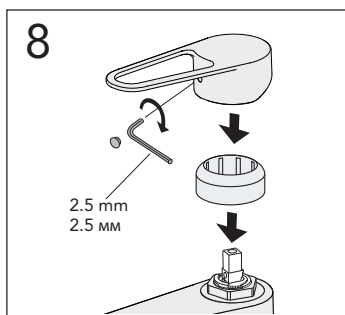
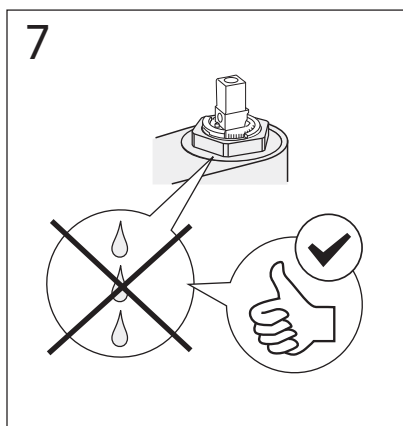
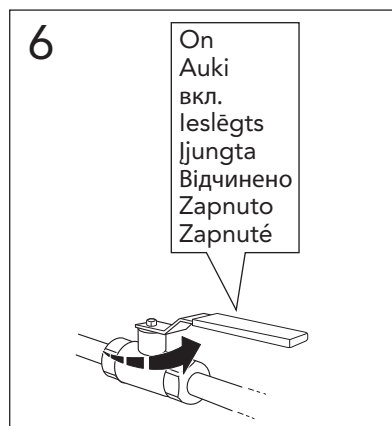
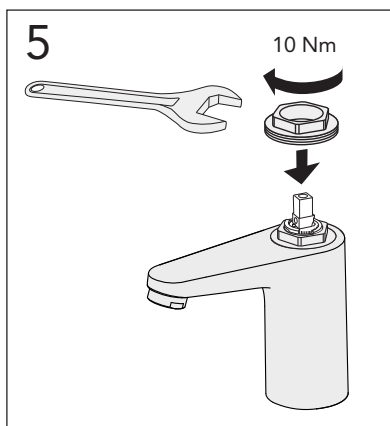
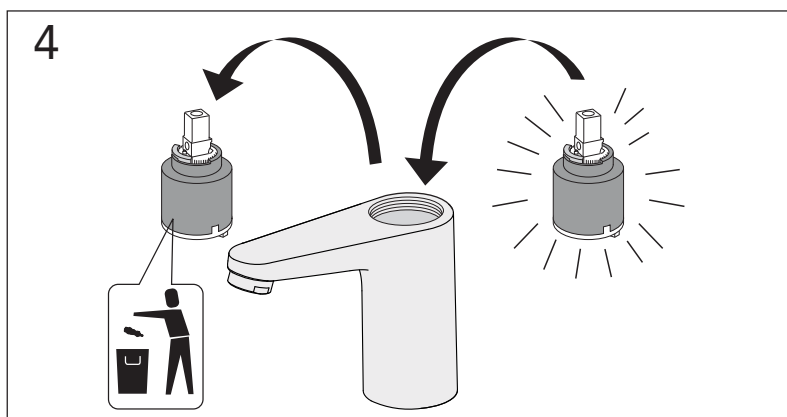
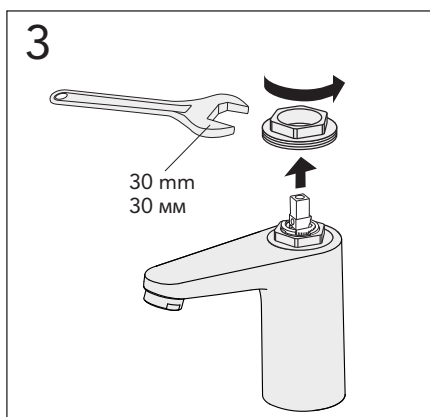
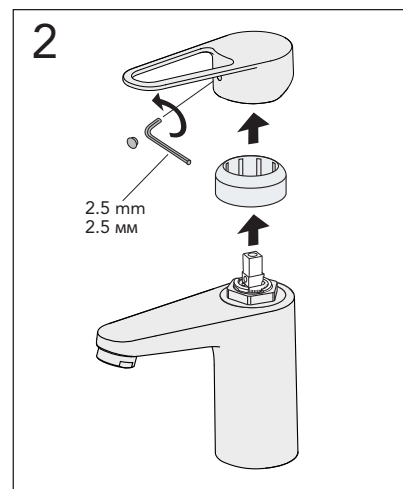
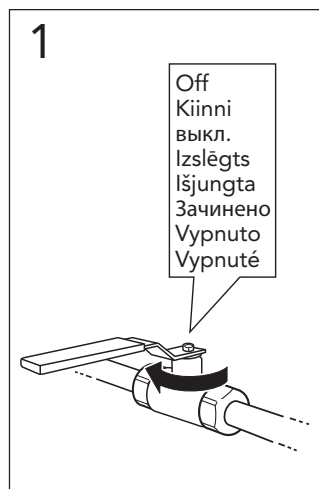
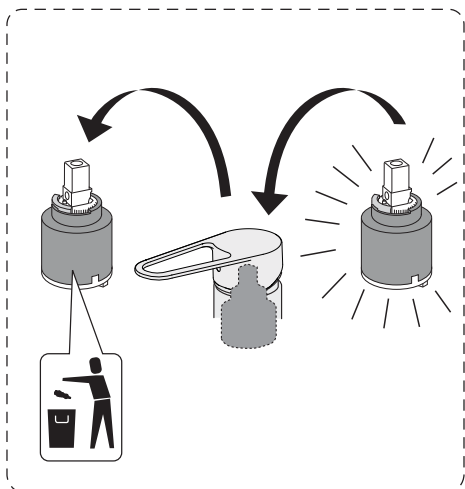



NAUTIC

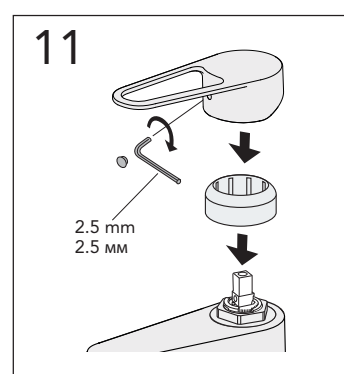
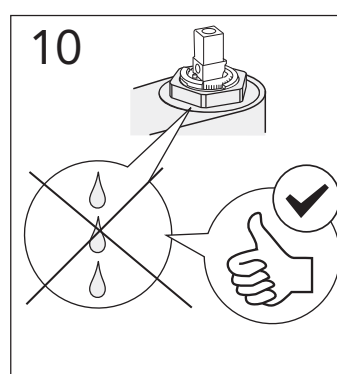
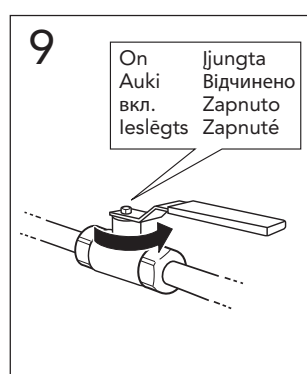
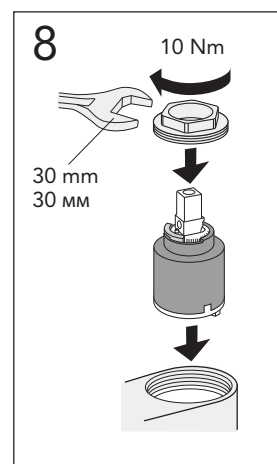
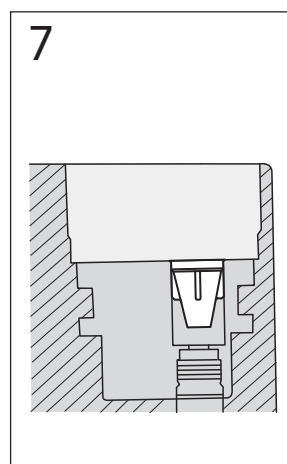
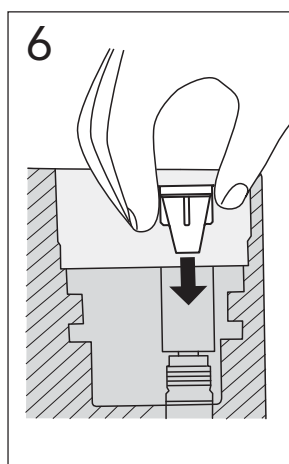
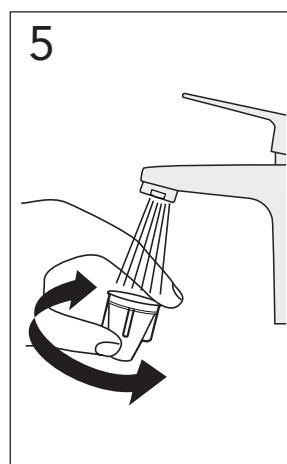
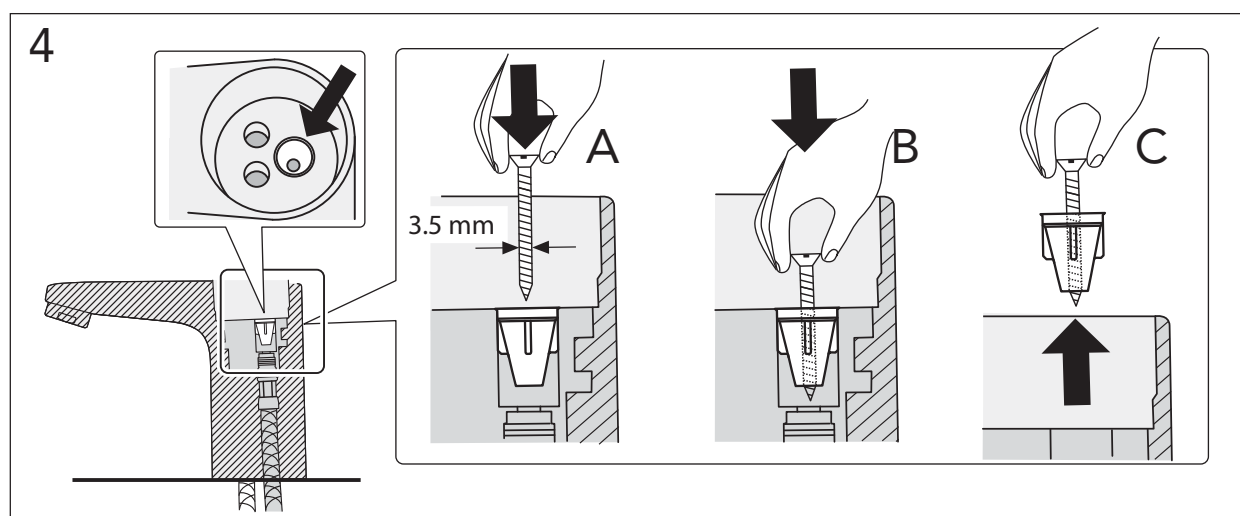
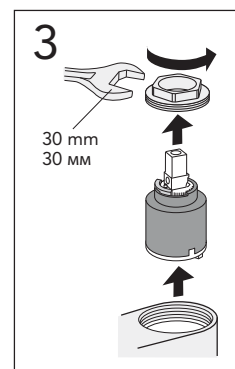
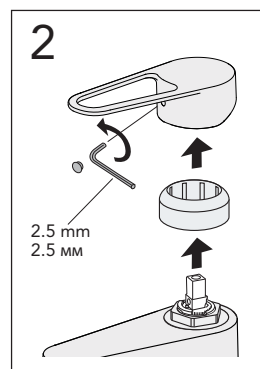
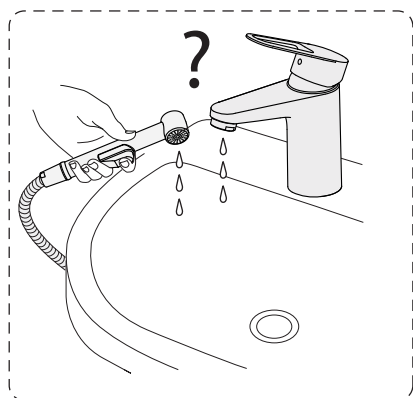



NAUTIC

Reservdelar
 Reservedeler
 Reservedele
 Varaosad
 Spare parts
 Varuosad
 Atsarginės dalys
 Rezerves Daļas
 ЗАПАСНЫЕ ЧАСТИ



ITEM NUMBER AND PRODUCT	DESCRIPTION	QTY. NUMBER	ITEM NUMBER
1 Lever-MIXER	Chrome		0811208121
2 CARTRIDGE			0811209121
3 NUT, LOCKWASHER package			0811209121
4 Ceramic package 35 mm, Square standard			0811207101
5 Ceramic package 35 mm, Square+ water-efficient			0811209121
6 Aerator	WGN 8		0811209121
7 Aerator	WGN L 4.3 5MM		0811209121
8 Surface base	Polished		0811209121
9 Surface base 30C steel	40, 510		0811209121
10 Mounting kit			0811209121
11 Shower hose, 80cm			0811209121
12 Hand shower	Soft-touch		0811209121

www.gustavsberg.com



A MEMBER OF THE
 VILLEROY & BOCH GROUP

Sweden
www.gustavsberg.com/se/

Denmark
www.gustavsberg.com/dk/

Norway
www.gustavsberg.com/no/

Suomi/Finland
www.gustavsberg.com/fi/

Estonia
www.gustavsberg.com/ee/

Latvia
www.gustavsberg.com/lv/

Lithuania
www.gustavsberg.com/lt/

Україна
www.gustavsberg.com/ua/

Россия
www.gustavsberg.com/ru/



Flödesbegränsare/Flow Restrictor

www.gustavsberg.com

Art nr: TC633577/1, 2023-08-23

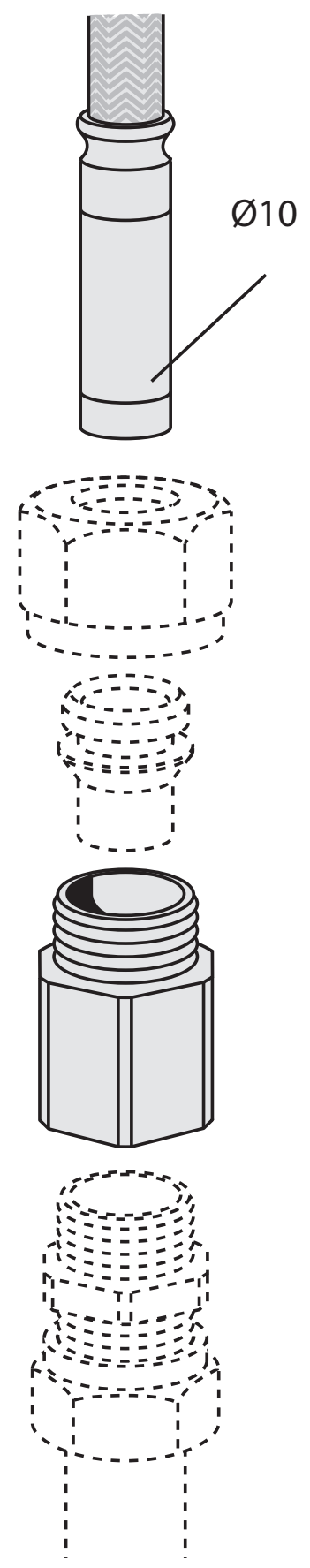
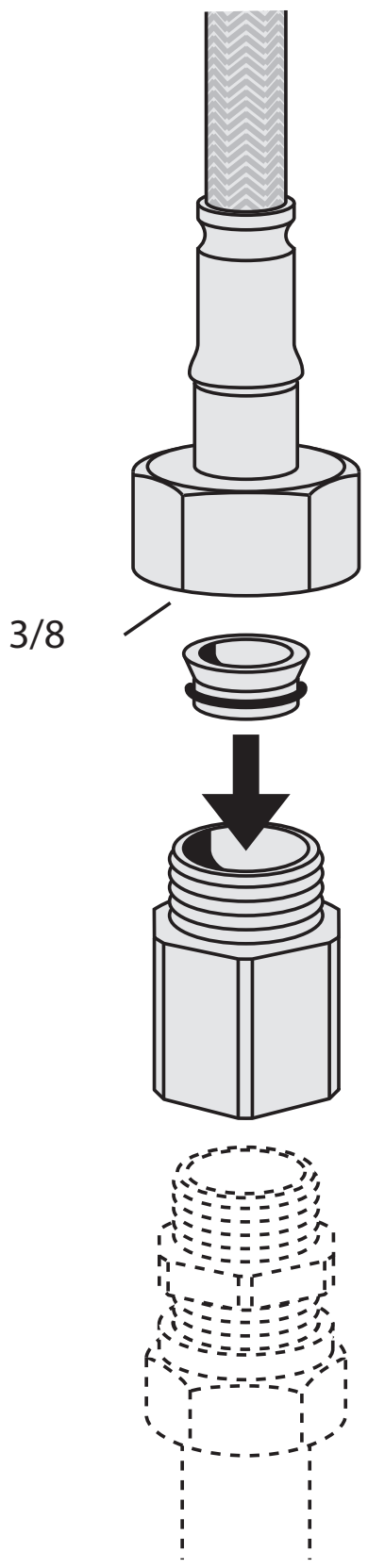

A MEMBER OF THE
VILLEROY & BOCH GROUP

www.gustavsberg.com