

DE	Gebrauchsanleitung / Montageanleitung	2
EN	Instructions for use / assembly instructions	4
DK	Brugsanvisning / Monteringsvejledning	6
FI	Käyttöohje / Asennusohje	8
NO	Bruksanvisning / Montasjeveiledning	10

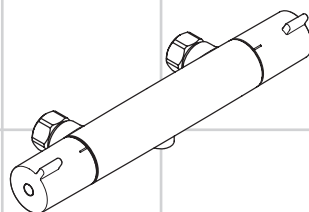

Ecostat 1001 CL

13213000

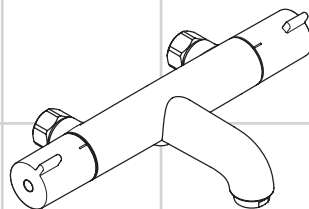

Ecostat 1001 CL

13214000



Sikkerhetshenvisninger

- △ Bruk hansker under montasjen for å unngå klem- og kuttskader.
- △ Dusjsystemet skal kun brukes for bade-, hygiene- og kroppshygiene.
- △ Barn og voksne med fysiske og psykiske og/eller sensoriske handicap skal ikke bruke dusjsystemet uten oppsyn. Personer som er påvirket av alkohol eller narkotika skal ikke bruke dusjsystemet.
- △ Store trykkdifferanser mellom kaldt- og varmtvannstilkoblinger skal utlignes.

Montagehenvisninger

- Før montasjen skal produktet sjekkes for transportskader. Etter monteringen aksepteres ikke noen transport- eller overflateskader.
- Produktet er ikke påtenkt for bruk sammen med et dampbad!
- Armaturen skal monteres iht. gyldige standarder. De skal spyles og sjekkes!
- Gjeldende retningslinjer for rørleggerarbeid i de enkelte land skal følges.

Termostat i forbindelse med gjennomstrømningsoverner

- Når det tilkobles en hånddusj, skal en eventuell allerede innbygd drossel i hånddusjen fjernes.
- Når det oppstår problemer med gjennomstrømningsoverner eller ved store trykkdifferanser skal den medfølgende drossel (artikkelnummer 97510000) monteres i kaldtvannsforsyningen.

Tekniske data

Driftstrykk	maks. 1 MPa
Anbefalt driftstrykk:	0,1 – 0,5 MPa
Prøvetrykk	1,6 MPa
(1 MPa = 10 bar = 147 PSI)	
Varmtvannstemperatur	maks. 80 °C
Anbefalt temperatur for varmt vann	65 °C
Termisk desinfisering:	maks. 70 °C / 4 min
• Egensikker mot tilbakeflyt	
• Produktet er utelukkende designet for drikkevann!	

Symbolbeskrivelse



Ikke bruk silikon som inneholder eddiksyre!



Justering (se side 14)

Etter avsluttet montering skal termostatsens utløpstemperatur kontrolleres. Det er nødvendig med korrektur når temperaturen målt ved uttaksstedet avviker fra temperaturen som er innstilt på termostaten.

max. **Safety Function** (se side 15) ≈ 42 °C

Takket være egenskapen "Safety Function" kan det forhåndsinnstilles en ønsket maks. temperatur, f.eks. 42 °C.



Vedlikehold (se side 18)

- For å holde regulerings-enheten bevegelig, skal termostaten stilles fra tid til annen på helt varmt og helt kaldt.
- Termostaten er utstyrt med returløpssperre. Funksjonen til returløpssperren skal iht. DIN EN 1717 og i samsvar med de nasjonale og lokale forskrifter sjekkes regelmessig (DIN 1988 en gang i året).



Betjening (se side 16)



Mål (se side 19)



Gjennomstrømningsdiagram

(se side 19)

- ① Dusj
- ② Badekar



Serviceedeler (se side 20)



Rengjøring (se vedlagt brosjyre)

Feil	Årsak	Feilrettelse
Lite vann	- Forsyningstrykk er ikke tilstrekkelig	- Ledningstrykk sjekkes
	- Smussfangersil skitten (96922000)	- Smussfangersil før termostaten og på reguleringsenheten rengjøres (96922000)
	- Dusjens silpakning er skitten	- Silpakning mellom dusj og slangen rengjøres
Krysstrømning, varmt vann presses ved lukket armatur inn i kaldtvannsledning eller omvendt	- Returløpstopper skitten / defekt	- Returløpstopper rengjøres, byttes hvis nødvendig
Utløpstemperatur samsvarer ikke med innstilt temperatur	- Termostat ble ikke justert	- Termostat justeres
	- For lav varmtvannstemperatur	- Varmtvannstemperatur økes til mellom 42 °C og 65 °C
Temperaturregulering er ikke mulig	- reguleringsenhet forkalket	- reguleringsenhet byttes
Dusj eller utløp drypper	- Smuss eller avleiringer på tetningen, avsperrings-overdel skadet	- Avsperrings-overdel rengjøres hhv. Byttes
Gjennomstrømningsovn innkobler ikke under termostatdrift	- Drossel til hånddusjen ikke fjernet	- Drossel fjernes fra hånddusjen
	- Smussfangersil skitten	- Smussfangersil rengjøres / byttes
	- Returløpstopper sitter fast	- Returløpstopper byttes



Montasje se side 12

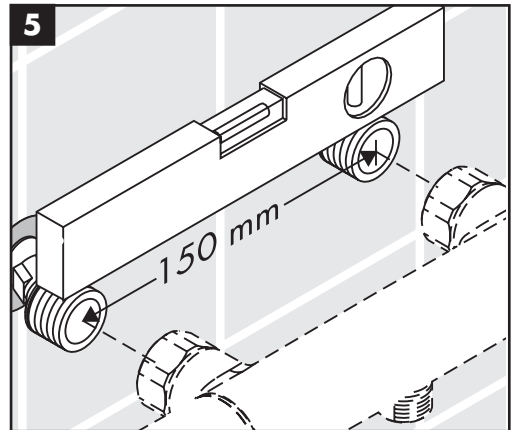
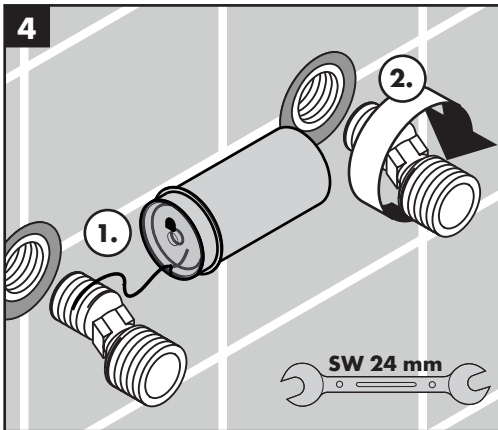
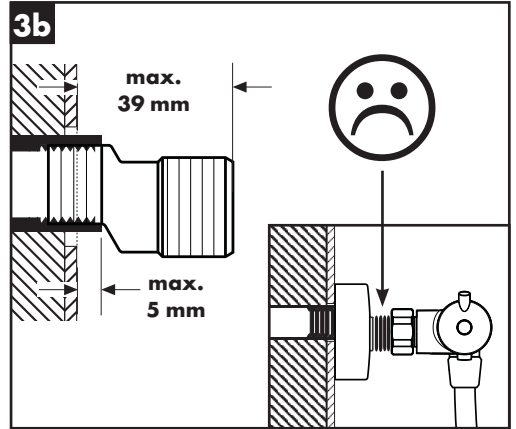
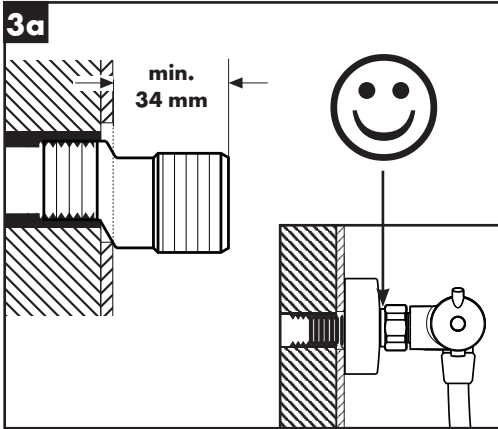
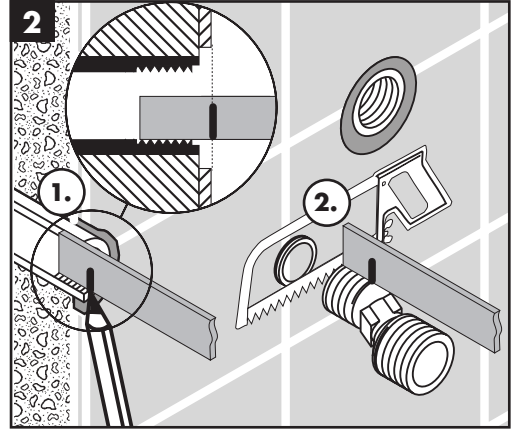
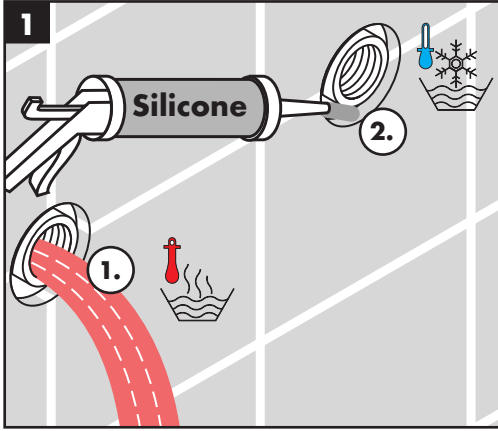

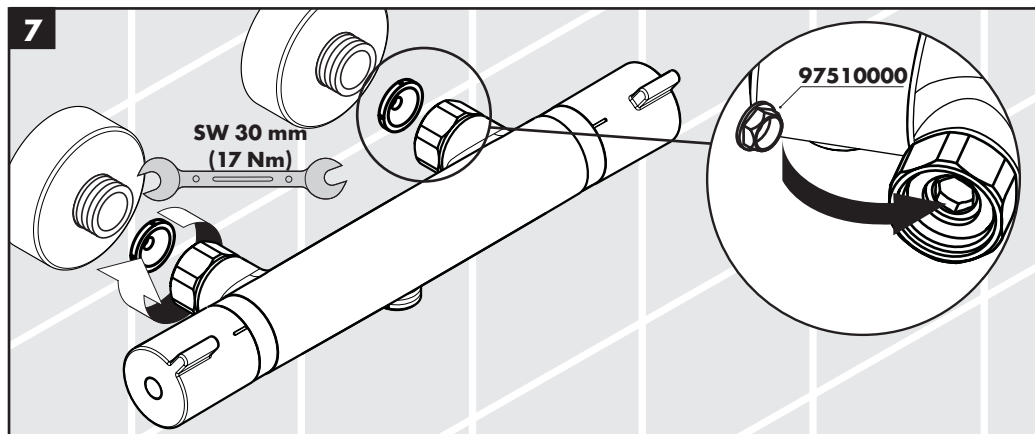
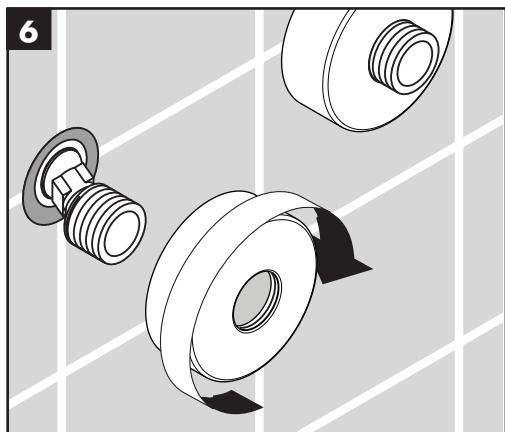

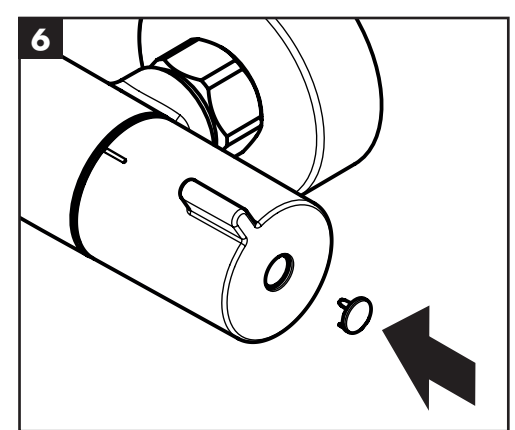
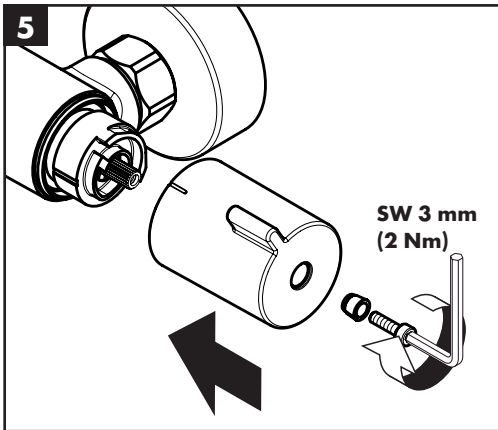
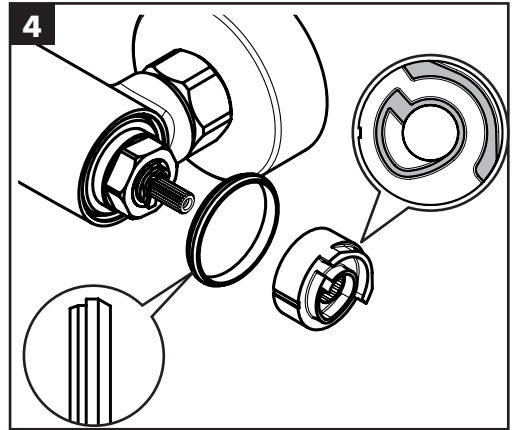
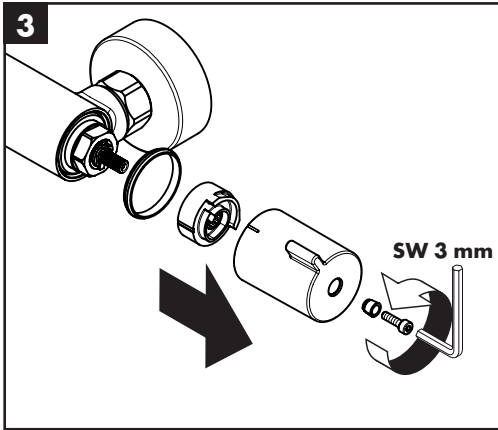
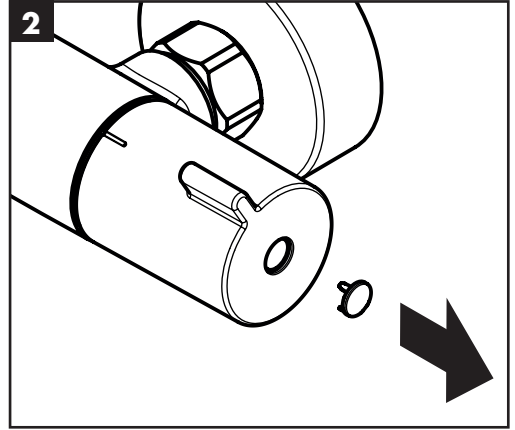
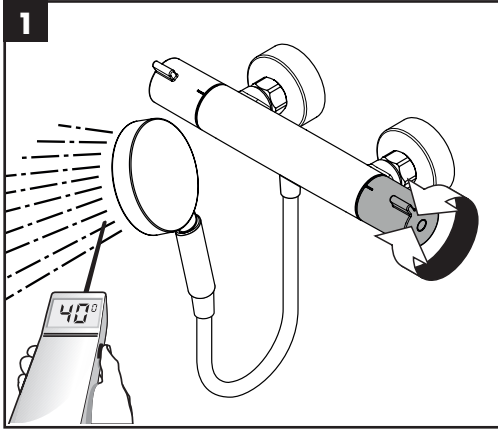

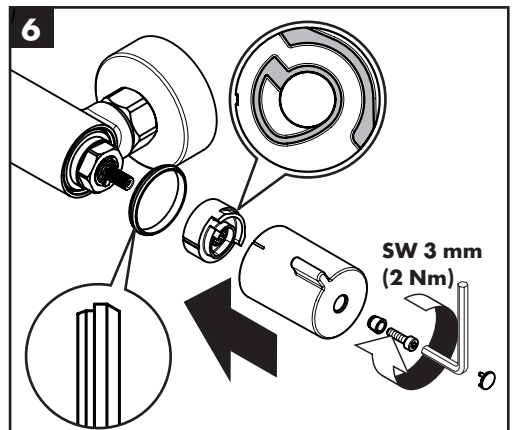
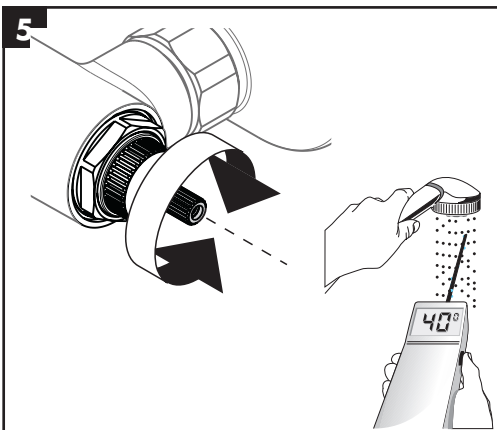
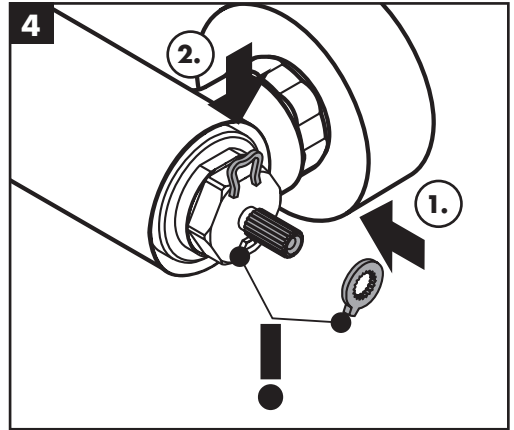
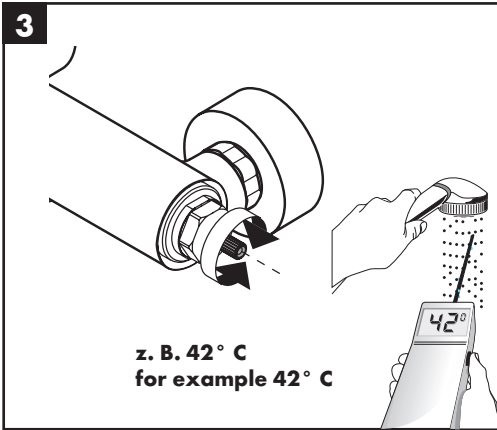
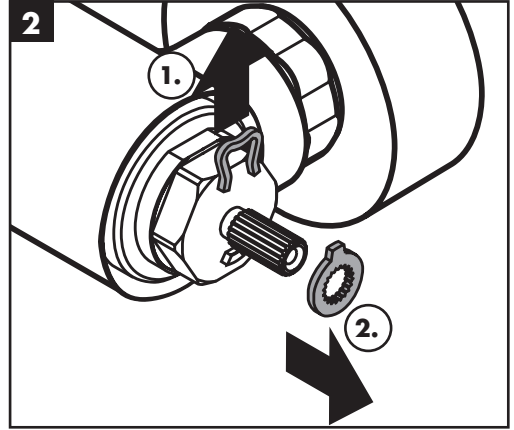
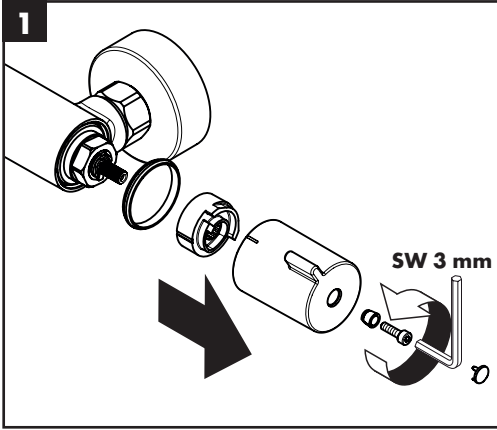

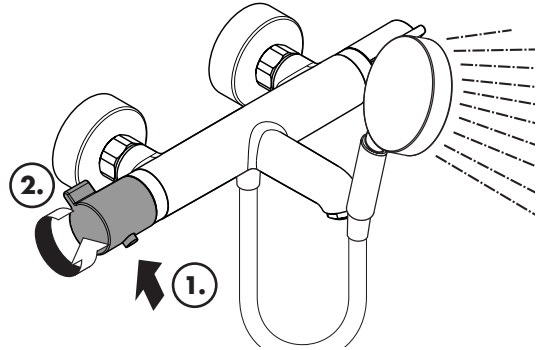
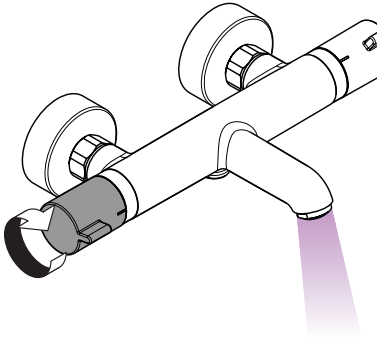

öffnen / open / åbne / avaaminen / åpne

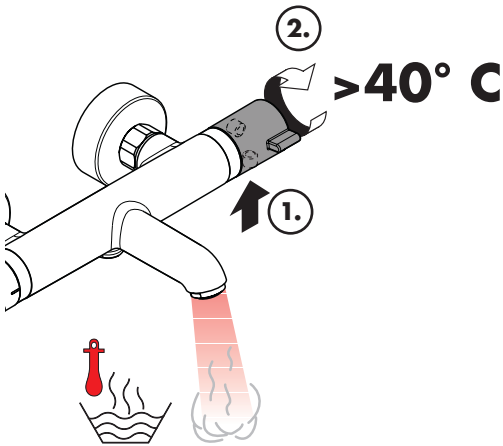

warm / hot / varmt / lämmin / varm

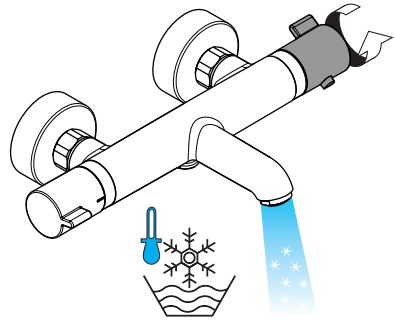

kalt / cold / freddo / kylmä / kaldt

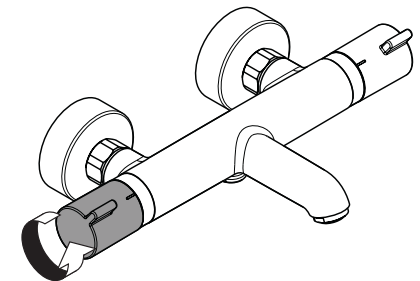

schließen / close / lukke / sulkeminen / lukke

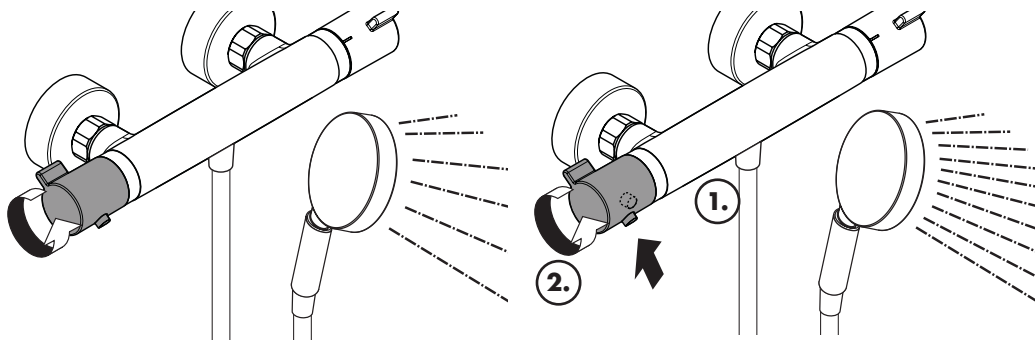

öffnen / open / åbne / avaaminen / åpne

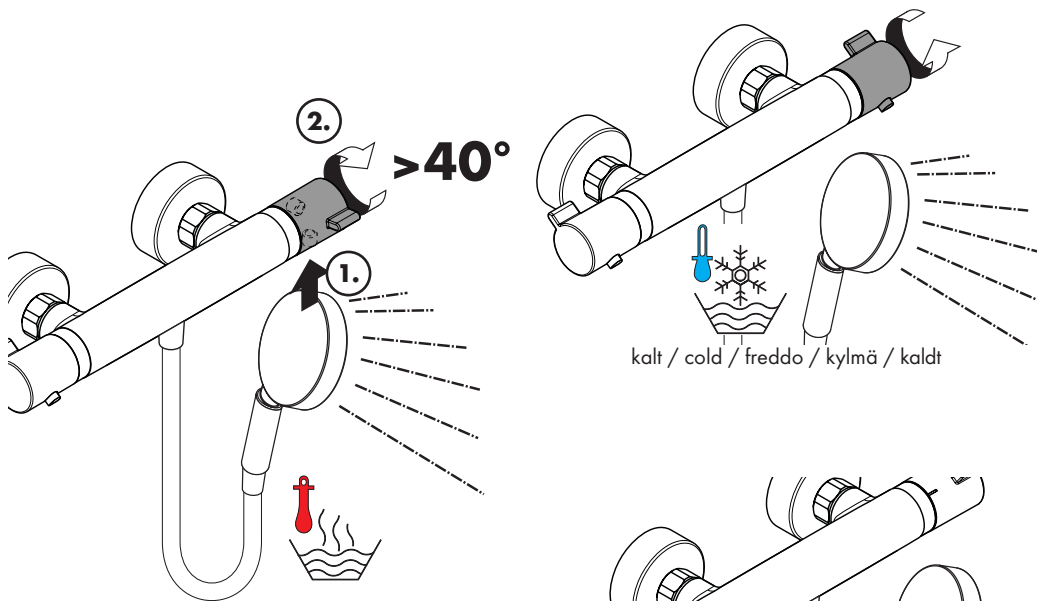

warm / hot / varmt / lämmin / varm

kalt / cold / freddo / kylmä / kaldt

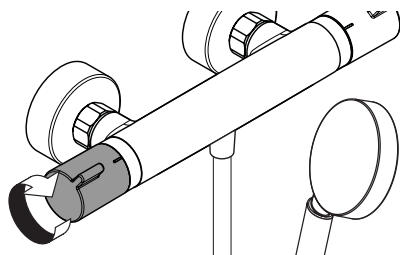

schließen / close / lukke / sulkeminen / lukke

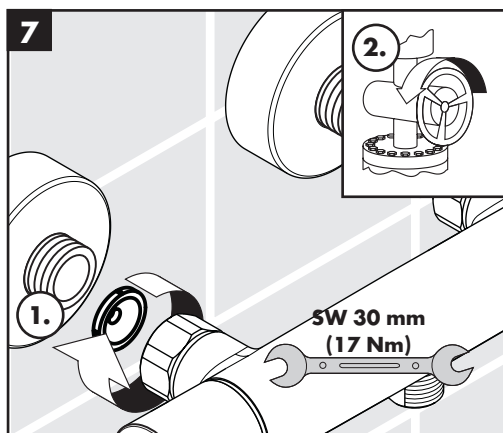
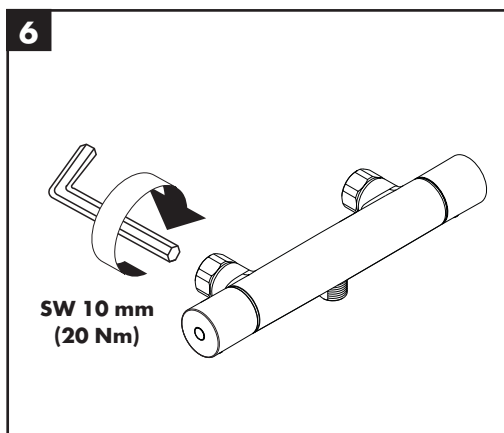
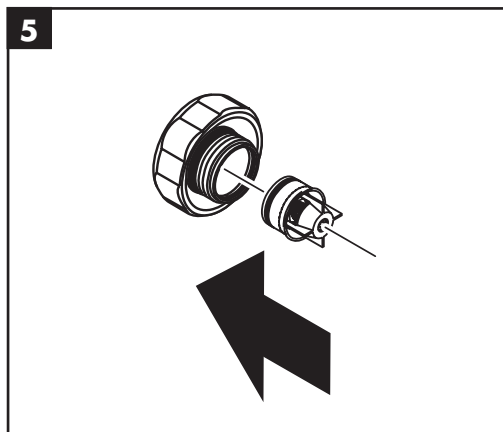
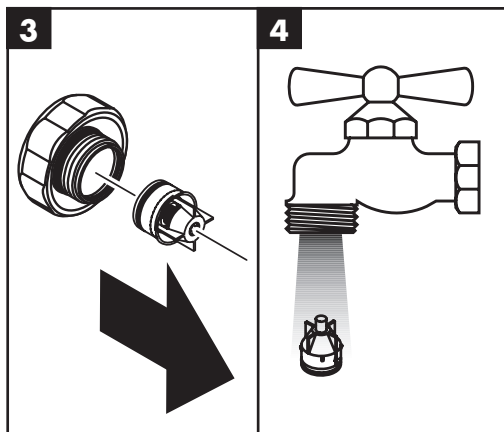
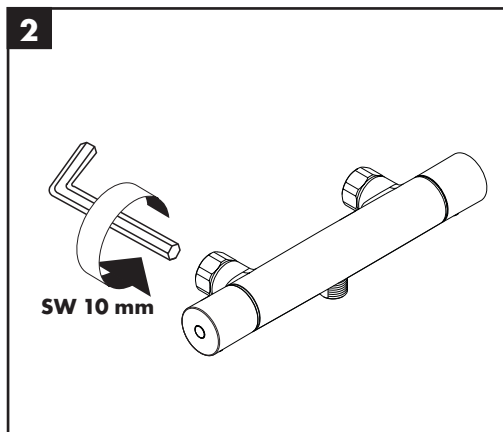
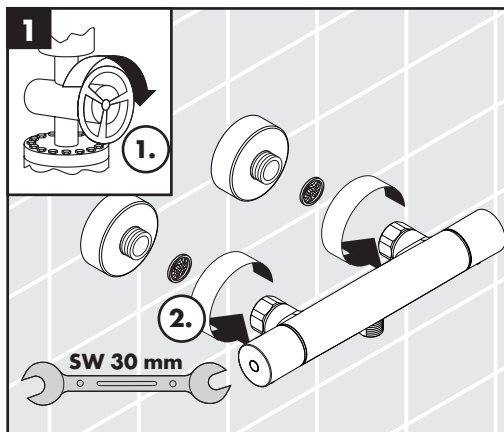



Ecostat 1001 CL

13213000

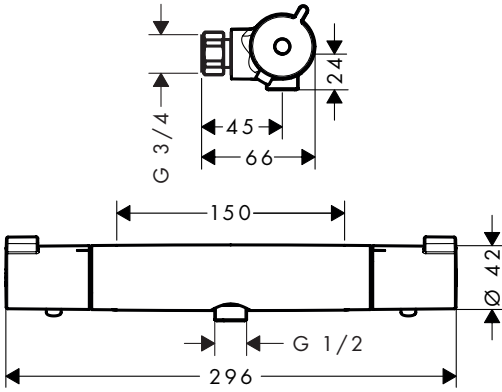

Ecostat 1001 CL

13214000

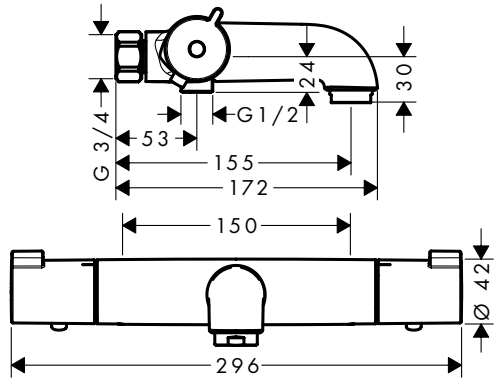

Ecostat 1001 CL

13213000

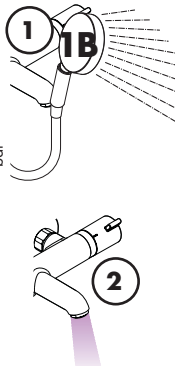
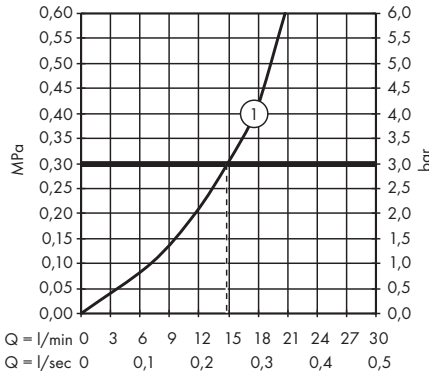

Ecostat 1001 CL

13214000

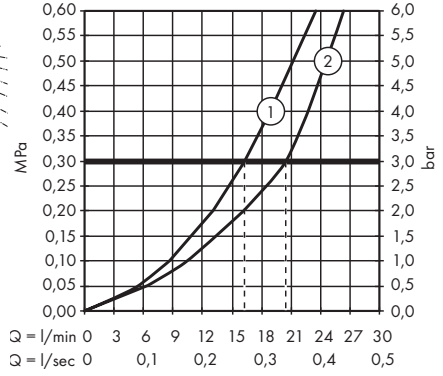



EcoStat 1001 CL

13214000

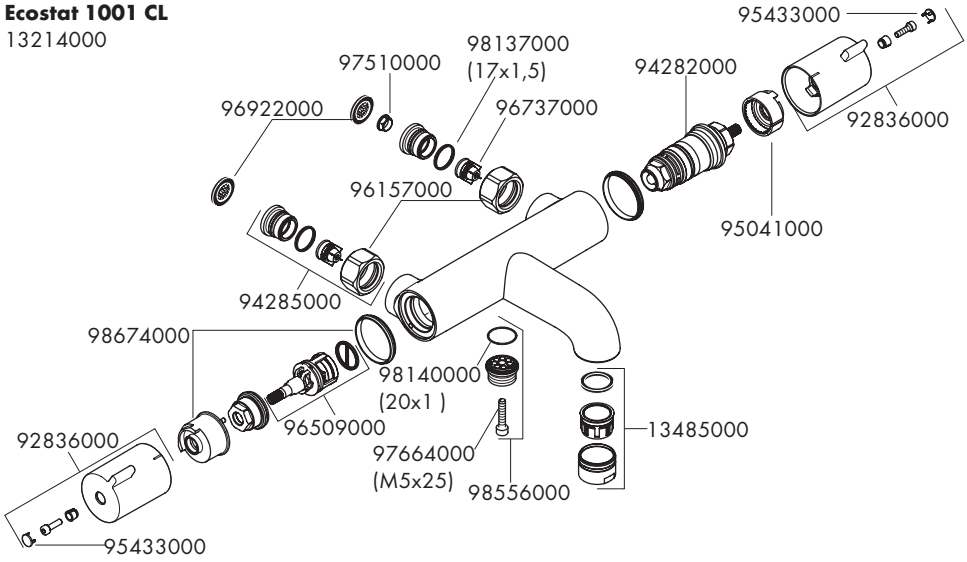

EcoStat 1001 CL

13213000

