

DE	Gebrauchsanleitung / Montageanleitung	2
FR	Mode d'emploi / Instructions de montage	3
EN	Instructions for use / assembly instructions	4
IT	Istruzioni per l'uso / Istruzioni per Installazione	5
ES	Modo de empleo / Instrucciones de montaje	6
NL	Gebruiksaanwijzing / Handleiding	7
DK	Brugsanvisning / Monteringsvejledning	8
PT	Instruções para uso / Manual de Instalação	9
PL	Instrukcja obsługi / Instrukcja montażu	10
CS	Návod k použití / Montážní návod	11
SK	Návod na použitie / Montážny návod	12
ZH	用户手册 / 组装说明	13
RU	Руководство пользователя / Инструкция по монтажу	14
FI	Käyttöohje / Asennusohje	15
SV	Bruksanvisning / Monteringsanvisning	16
LT	Vartotojo instrukcija / Montavimo instrukcijos	17
HR	Upute za uporabu / Uputstva za instalaciju	18
TR	Kullanım kılavuzu / Montaj kılavuzu	19
RO	Manual de utilizare / Instrucțiuni de montare	20
EL	Οδηγίες χρήσης / Οδηγία συναρμολόγησης	21
SL	Navodilo za uporabo / Navodila za montažo	22
ET	Kasutusjuhend / Paigaldusjuhend	23
LV	Lietošanas pamācība / Montāžas instrukcija	24
SR	Uputstvo za upotrebu / Uputstvo za montažu	25
NO	Bruksanvisning / Montasjeveiledning	26
BG	Инструкция за употреба / Ръководство за монтаж	27
SQ	Udhëzuesi i përdorimit / Udhëzime rreth montimit	28
AR	دليل الاستخدام / تعليمات التجميع	29
HU	Használati útmutató / Szerelési útmutató	30

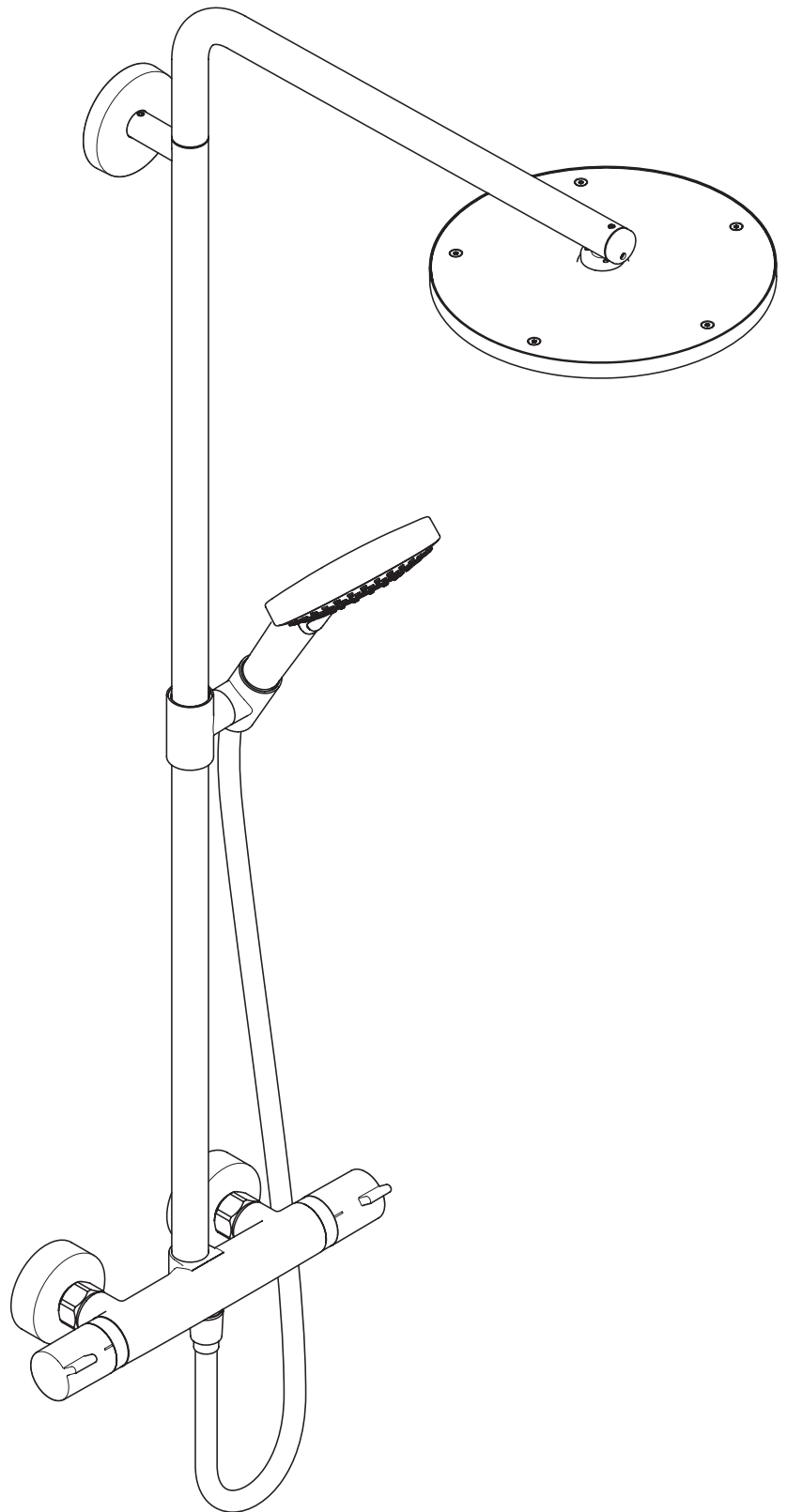

Showerpipe 240 1jet P
27633XXX



Sikkerhetshenvisninger

- △ Bruk hansker under montasjen for å unngå klem- og kuttskader.
- △ Produktet skal kun brukes for bade-, hygiene- og kroppshygiene.
- △ Armen til hodedusjen er kun laget for å holde hodedusjen. Den må ikke belastes med andre gjenstander!
- △ Barn og voksne med fysiske og psykiske og/eller sensoriske handicap skal ikke bruke dusjsystemet uten oppsyn. Personer som er påvirket av alkohol eller narkotika skal ikke bruke dusjsystemet.
- △ Dusjstrålen skal ikke komme i kontakt med ømfintlige kroppsdeler (f.eks. øynene). Overhold en tilstrekkelig avstand mellom dusjen og kroppen.
- △ Produktet skal ikke brukes som holdegrep. Det skal monteres en separat holdegrep.
- △ Store trykkdifferanser mellom kaldt- og varmtvannstilkoblinger skal utlignes.

Montagehenvisninger

- Før montasjen skal produktet sjekkes for transportskader. Etter monteringen aksepteres ikke noen transport- eller overflateskader.
- Ledningene og armaturen skal monteres, spyles og sjekkes iht. de gyldige normer.
- Gjeldende retningslinjer for rørleggerarbeid i de enkelte land skal følges.
- Monteringsmål i monteringsveiledningen er beregnet for personer som er omtrent 1800 mm høye, målene skal eventuell tilpasses om nødvendig. Her skal man passe på at ved endrede monteringsmålene blir minstehøyden endret, og det må tas hensyn til de endrede tilkoblingsmålene.
- Under monteringen av produktet gjort av kvalifisert fagperson, skal man påse at monteringsoverflaten på hele festeområdet er plant (ingen utstikkende fuger eller flisekanter), at veggoppbyggingen egner seg for produktmontasjen og ikke viser svake punkter.
- Den forhåndsmonterte filterinnsatsen skal brukes for å garantere hånddusjens standardgjennomstrømning og for å forhindre smussinnspylinger fra ledningsnettet. Smussinnspylinger kan påvirke funksjonen negativt og/eller føre til skader på hånddusjens funksjonsdeler. Hansgrohe påtar seg inget ansvar for skader som resulteres av dette.
- Produktet er ikke påtenkt for bruk sammen med et dampbad!
- I en nødsituasjon kan røret kortes ned i området nedenfor, mellom armaturen og hodedusjen ved hjelp av en fin sag.
- Når det oppstår problemer med gjennomstrømningsvannvarmer eller ved store trykkdifferanser skal det monteres en drossel i kaldtvannsforsyningen. Denne kan leveres som ekstratstyr (artikkelnummer 97510000).

Tekniske data

Driftstrykk	maks. 1 MPa
Anbefalt driftstrykk:	0,1 - 0,5 MPa
Prøvetrykk	1,6 MPa
	(1 MPa = 10 bar = 147 PSI)
Varmtvannstemperatur	maks. 70 °C
Anbefalt temperatur for varmt vann	65 °C
Tilkoblingsmål:	150±12 mm
Tilkoblinger G 1/2:	kaldt høyre - varm venstre
Termisk desinfisering:	maks. 70 °C / 4 min

- Egensikker mot tilbakeflyt
- Produktet er utelukkende designet for drikkevann!

Symbolbeskrivelse



Ikke bruk silikon som inneholder eddiksyre!

max. ≈ 42 °C Safety Function (se side 34)

Takket være egenskapen "Safety Function" kan det forhåndsinnstilles en ønsket maks. temperatur, f.eks. 42 °C.



Justering (se side 34)

Etter avsluttet montering skal termostatsens utløpstemperatur kontrolleres. Det er nødvendig med korrektur når temperaturen målt ved uttaksstedet avviker fra temperaturen som er innstilt på termostaten.



Vedlikehold (se side 38)

- Funksjonen til returløpssperren skal iht. DIN EN 1717 og i samsvar med de nasjonale og lokale forskrifter sjekkes regelmessig (minst en gang i året).
- For å holde regulerings-enheten bevegelig, skal termostaten stilles fra tid til annen på helt varmt og helt kaldt.



Mål (se side 39)



Gjennomstrømningsdiagram (se side 39)



Servicedeler (se side 31)

Ekstratilbehør (ikke med i leveransen)



Utligningsskive for fliser Krom #98681000 (se side 31)



Rengjøring (se side 36)



Betjening (se side 35)

Sett dusjhodet litt på skrå for å tømme det etter bruk.



Prøvemerket (se side 40)

Feil	Årsak	Feilrettelse
Lite vann	- Forsyningstrykk er ikke tilstrekkelig - Smussfangersil til reguleringseheten skitten. (#96922000) - Dusjens filterinnsats er skitten	- Ledningstrykk sjekkes - Smussfangersil før termostaten og på regulerings-enheten rengjøres - rengjøring filterinnsats mellom dusj og slangen
Krysstrømning, varmt vann presses ved lukket armatur inn i kaldtvannsledning eller omvendt	- Returløpstopper skitten / defekt	- Returløpstopper rengjøres, byttes hvis nødvendig
Utløpstemperatur samsvarer ikke med innstilt temperatur	- Termostat ble ikke justert - For lav varmtvannstemperatur	- Termostat justeres - Varmtvannstemperatur økes til mellom 42 °C og 65 °C
Temperaturregulering er ikke mulig	- reguleringsenhet forkalket	- reguleringsenhet byttes
gjennomstrømningsvannvarmer innkobler ikke under termostatdrift	- Smussfangersil skitten - Returløpstopper sitter fast - Drossel til hånddusjen ikke fjernet	- Smussfangersil rengjøres / byttes - Returløpstopper byttes - Drossel fjernes fra hånddusjen

Showerpipe 240 1jet P

27633XXX

XXX =Farbcodierung / Couleurs / Colors / Trattamento / Acabados / Kleuren / Overflade/ Acabamentos / Kody kolorów / Kód povrchové úpravy / Farebné označenie / 颜色代码 / Цветная кодировка / Színkódolás / Värnikoodaus / Färgkodning / Spalvos / Boje / Renkler / Coduri de culori / Χρώματα / Barve / Värvid / Krāsu kodī / Označe boja / Fargekode / Цветово кодиране / Kodimi me anë të ngjyrave / الألوان

000 = Chrome

140 = Brushed Bronze

340 = Brushed Black Chrome

670 = Matt Black

700 = Matt White

990 = Polished Gold-Optic

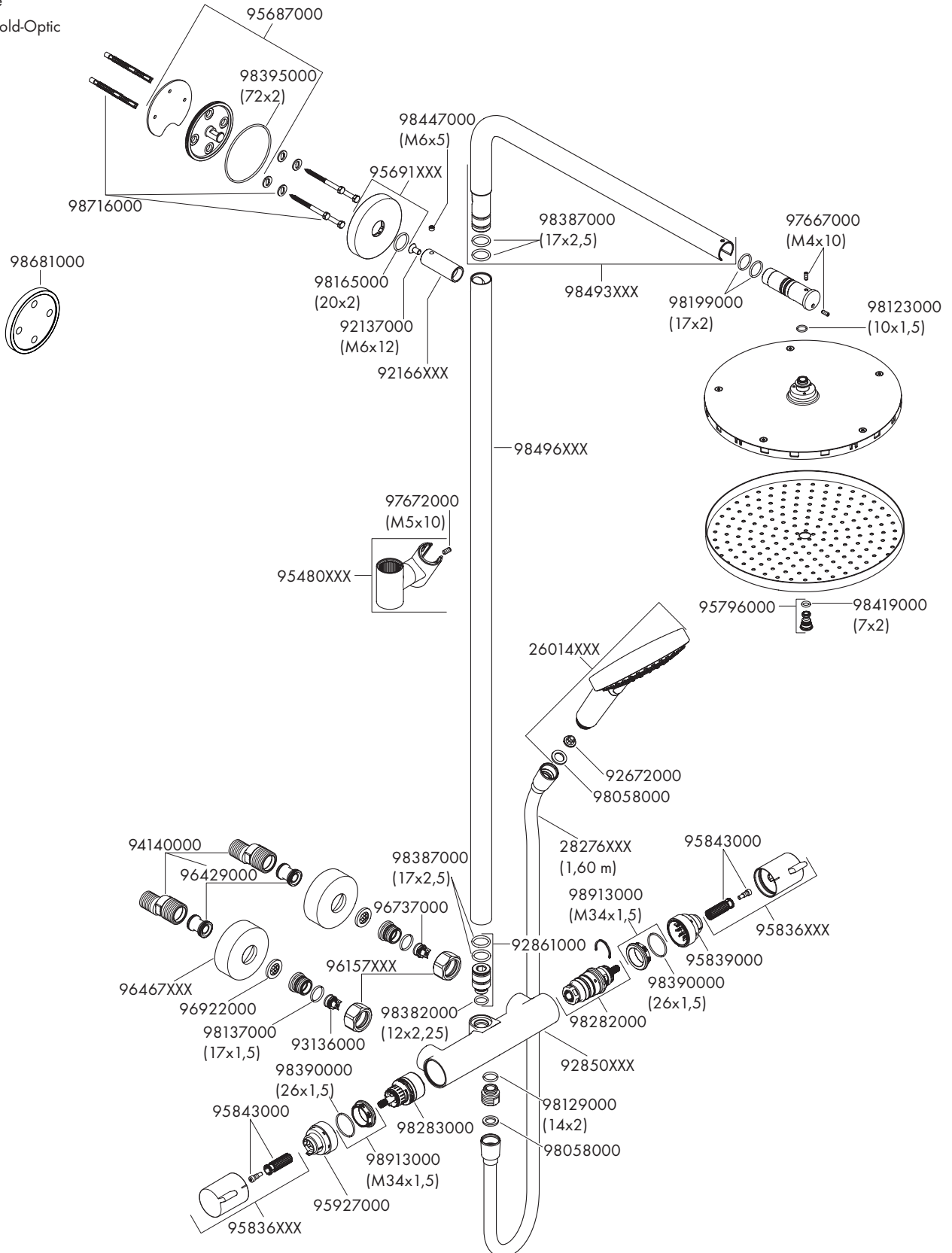

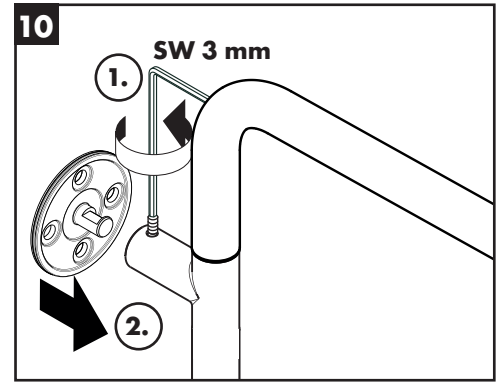
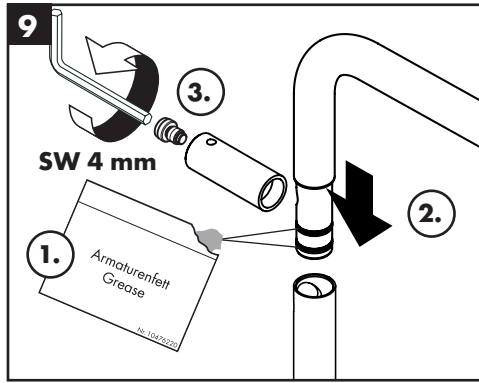
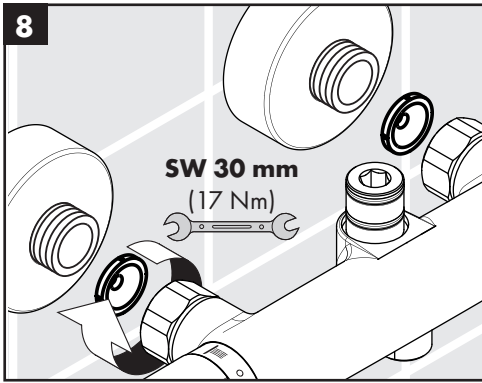
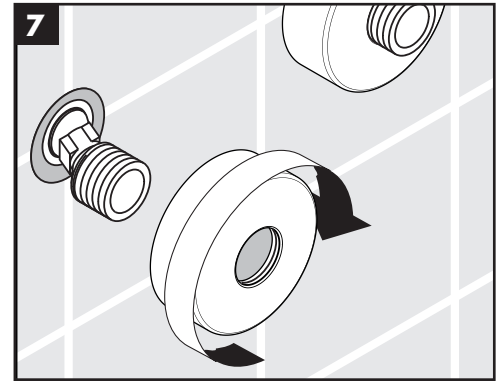
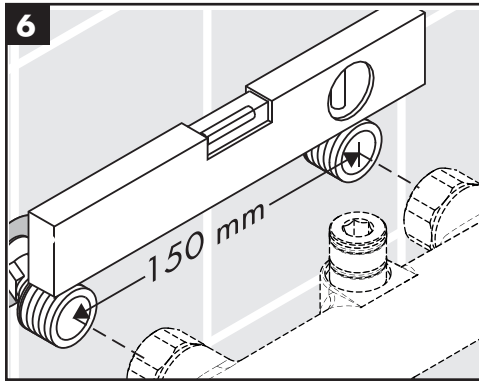
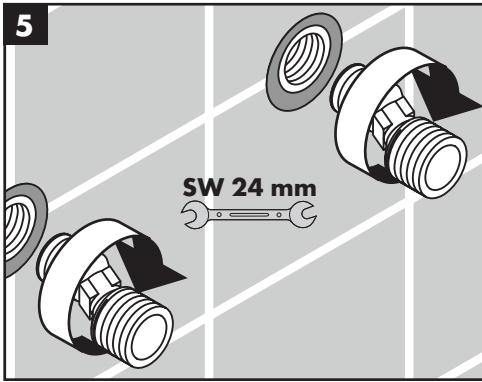
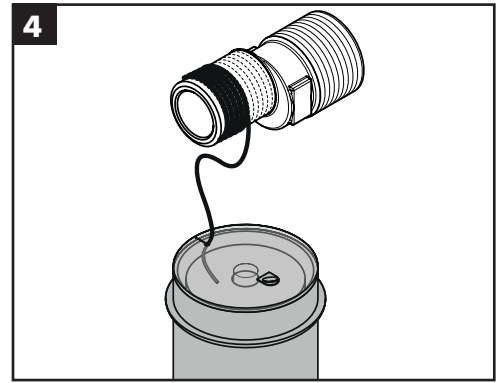
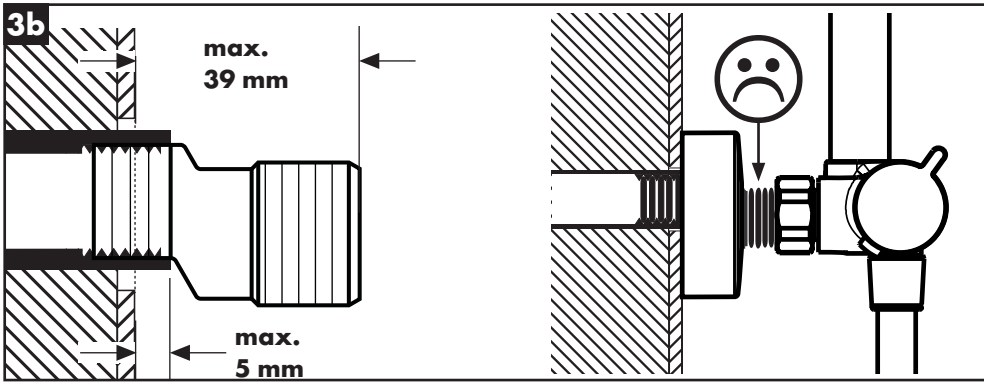
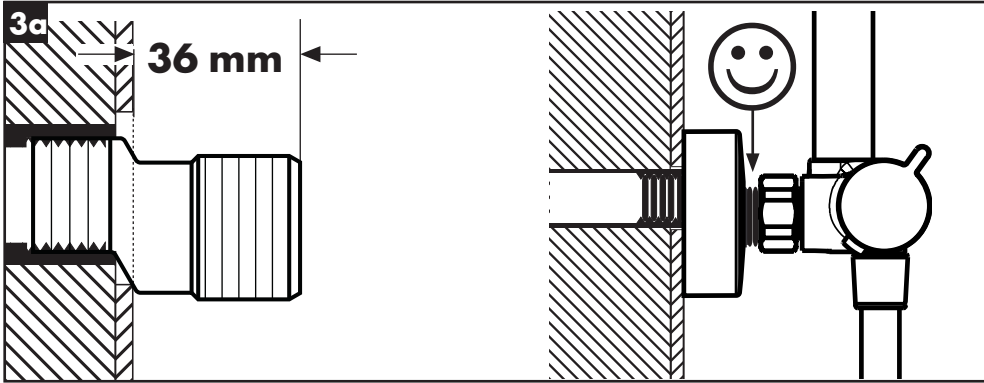
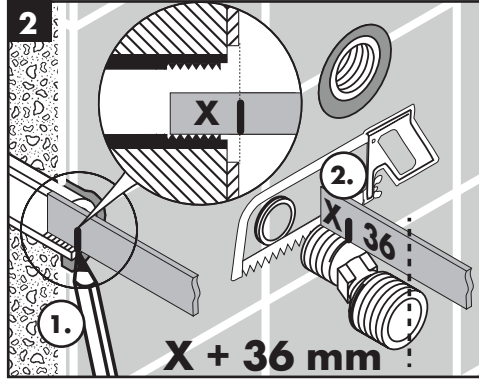
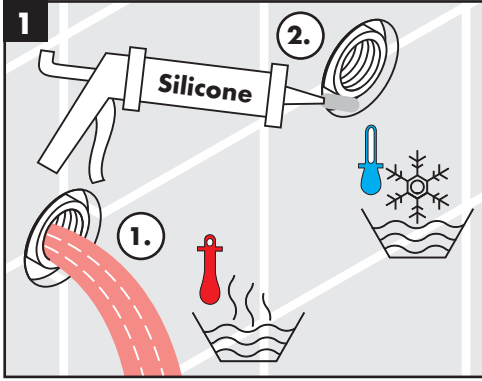

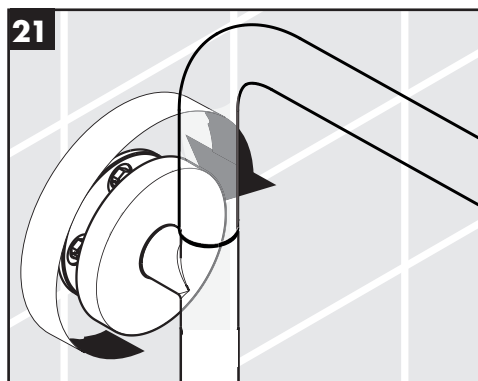
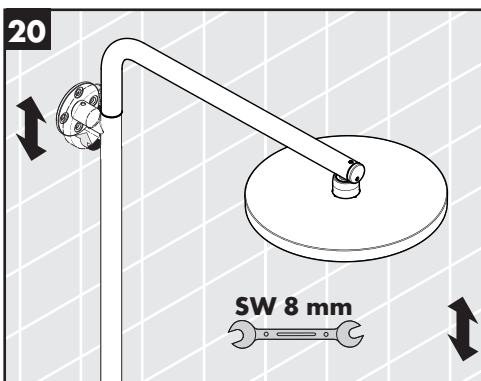
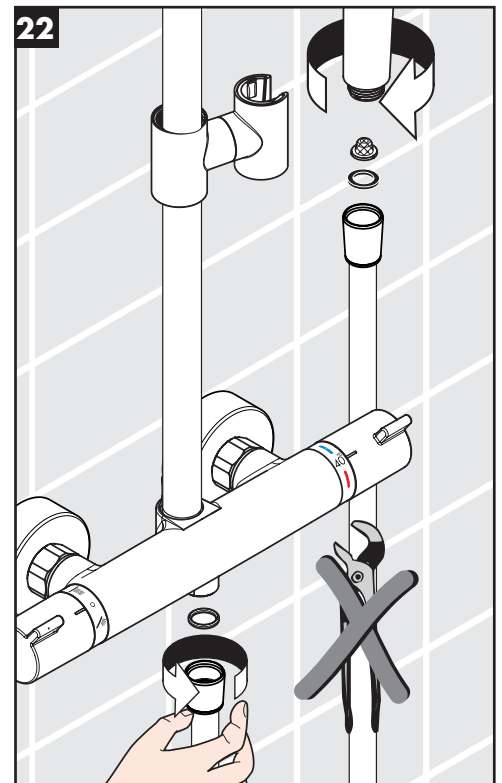
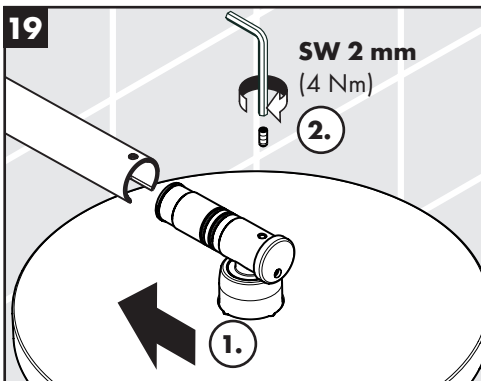
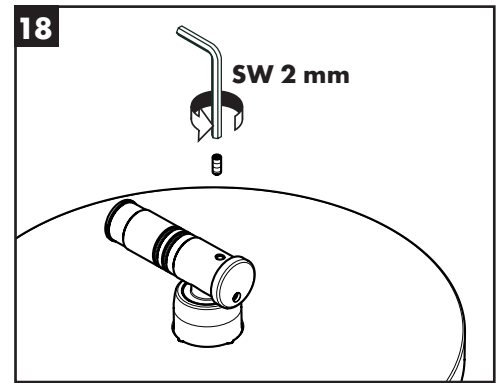
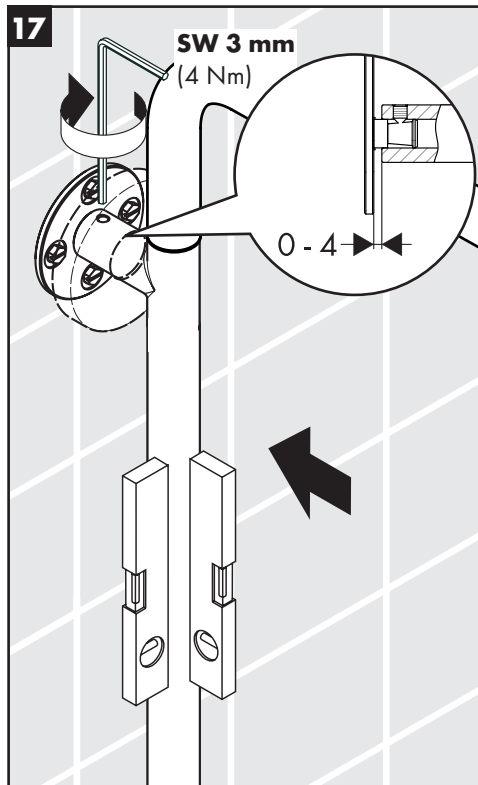
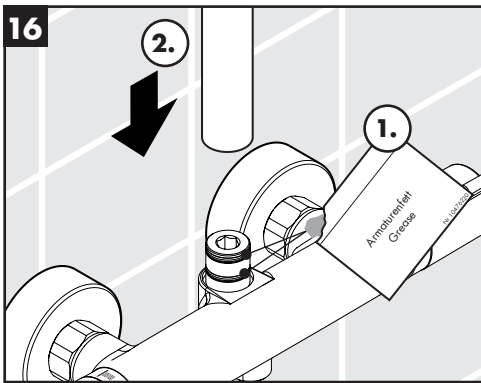
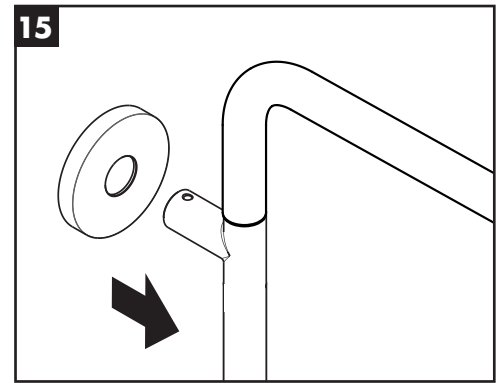
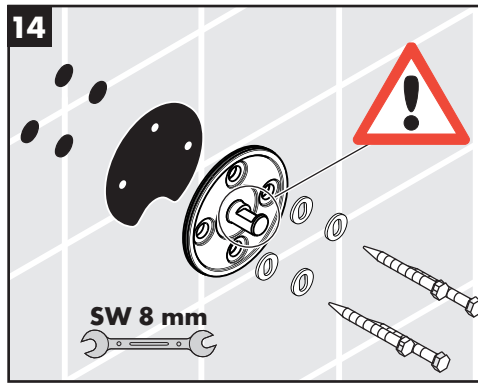
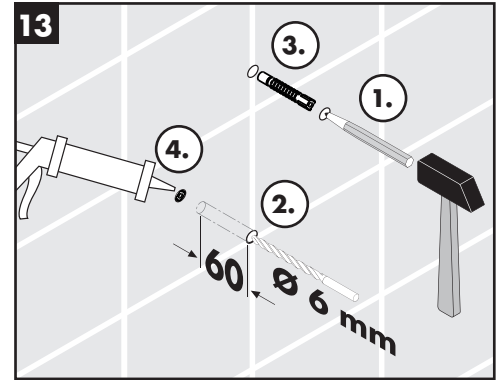
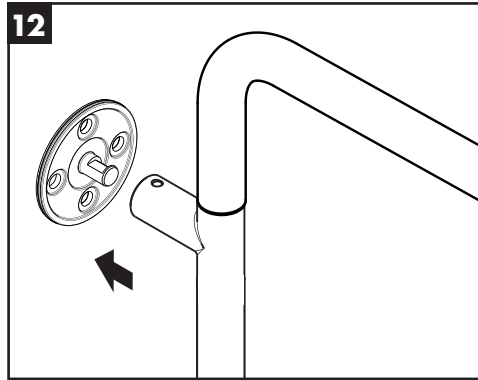
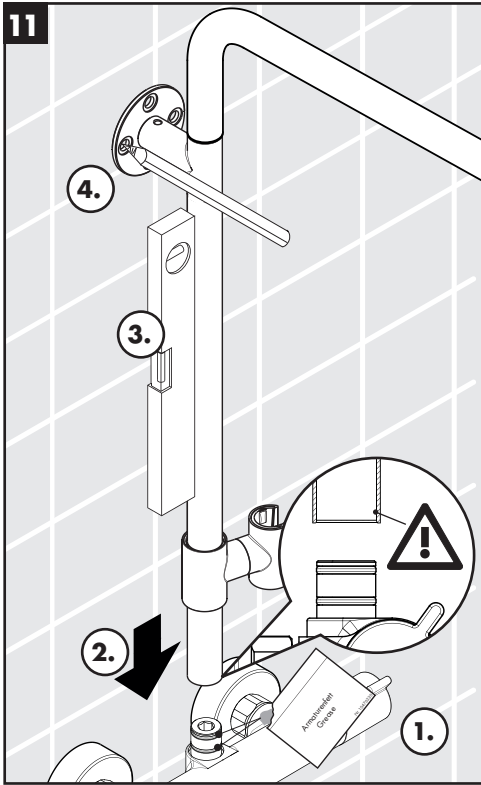

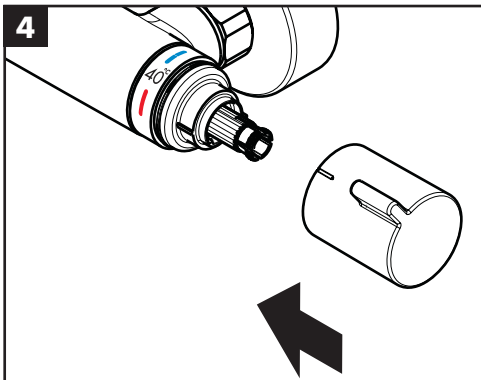
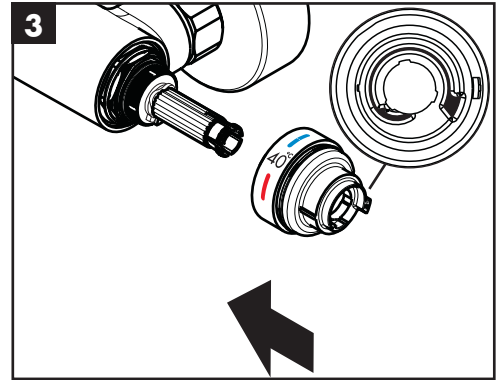
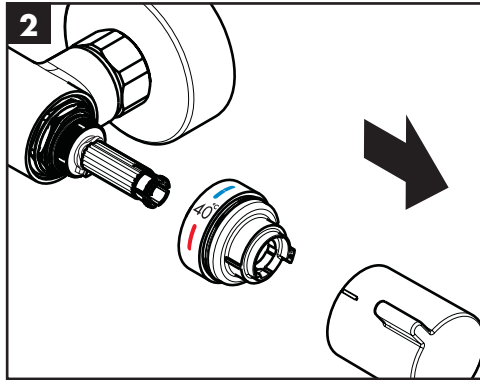
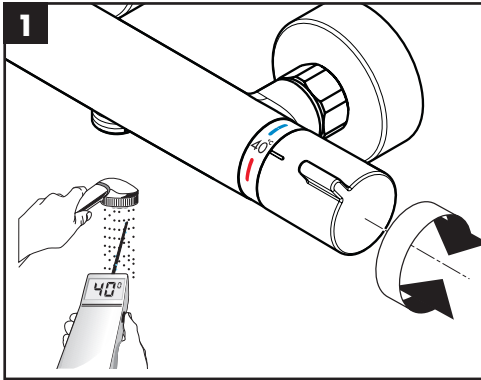

max.
≈ 42 °C

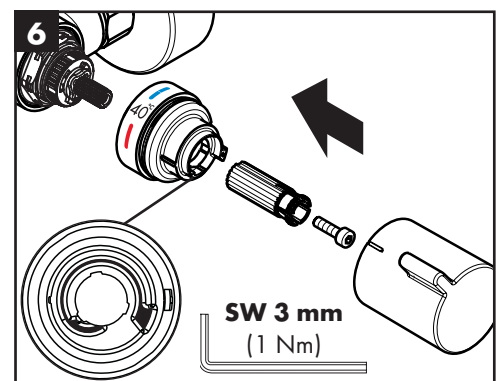
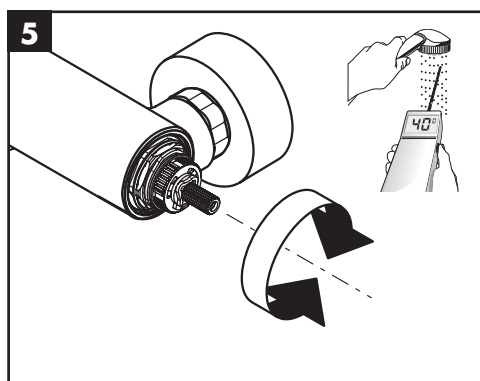
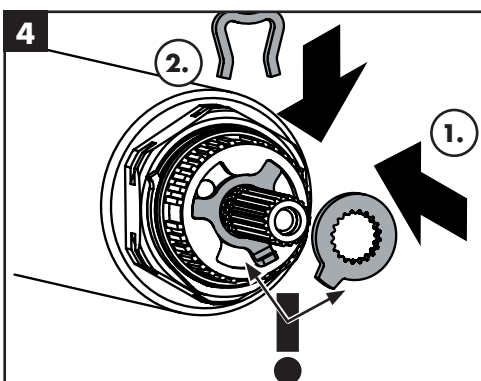
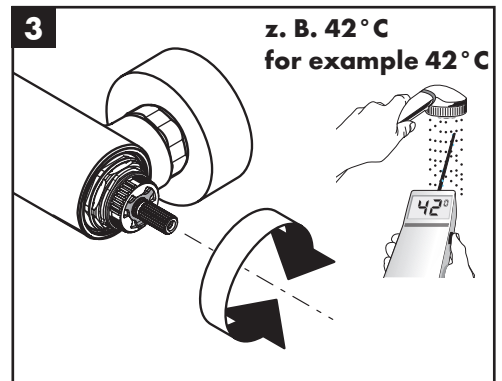
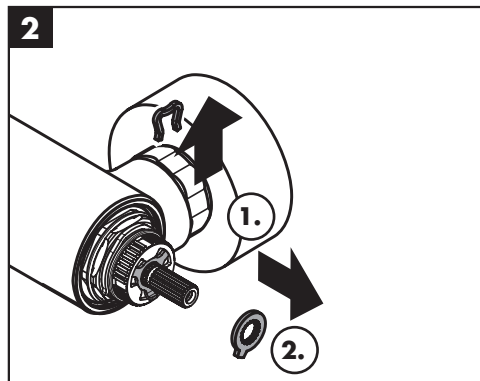
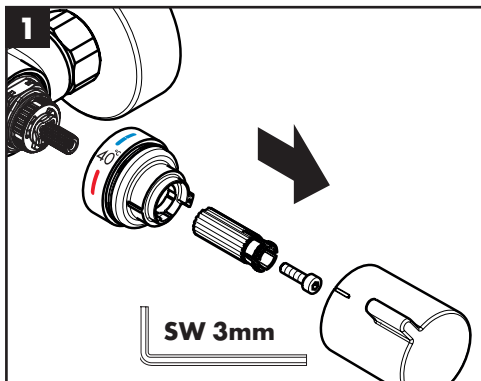

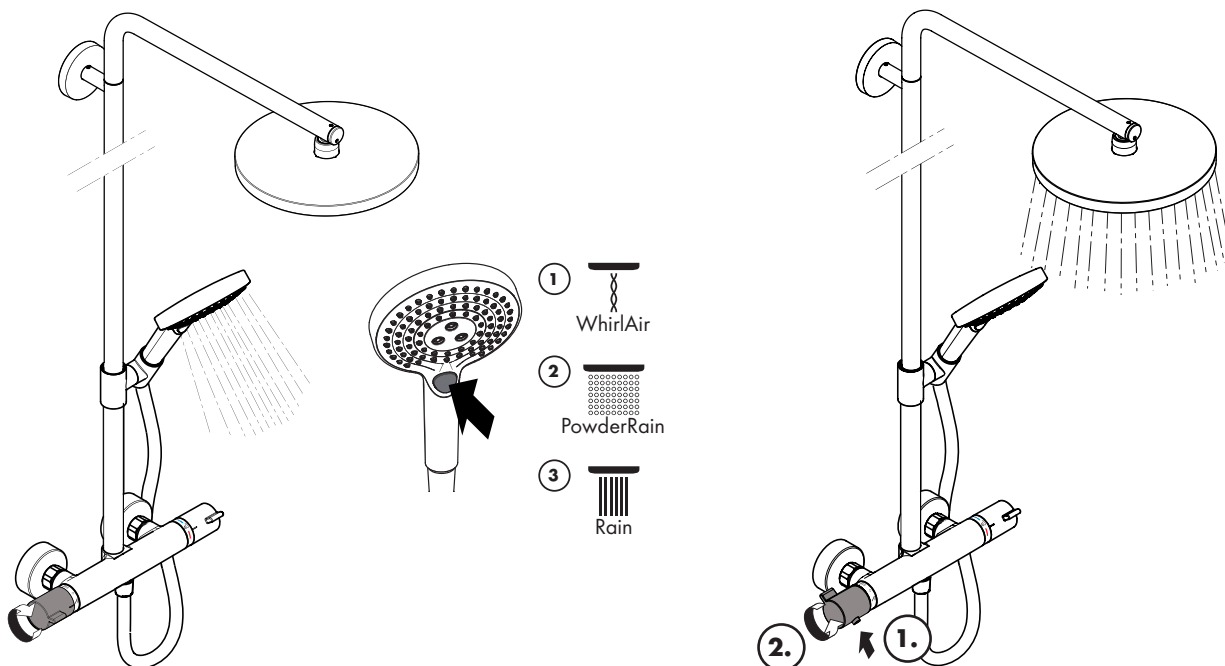

öffnen / ouvert / open / aperto / abierto / open / åbne / abrir / otworzyć / otevřít / otvorit / 开 / открыть / nyitás / авааминен / öppna / atidaryti / Отваранье / açmak / deschide / ανοικτό / odpreti / avage / atvērt / otvoriti / árne / отваряне / hare / فتح

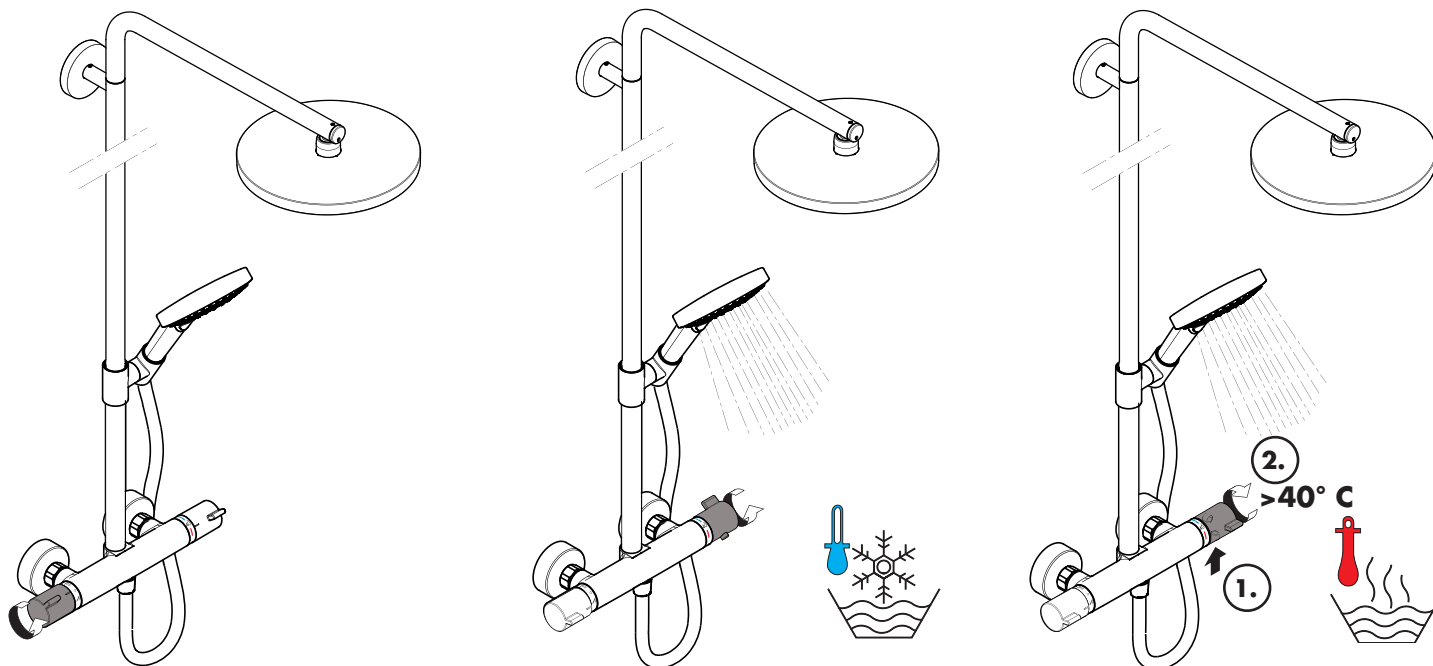

schließen / fermé / close / chiudere / cerrar / sluiten / lukke / fechar / zamknąć / zavřít / uzavrieť / 关 / закрыть / bezárás / sulkeminen / stänga / uždaryti / Затваранье / kapatmak / închide / κλειστό / zapreti / sulgege / aizvērt / zatvori / lukke / затваряне / mbylle / إغلاق

kalt / froid / cold / freddo / frío / koud / koldt / fria / zimna / studená / studená / 冷 / холодная / hideg / kylmä / kallt / šaltas / Hladno / soğuk / rece / крѹо / mrzlo / külm / auksts / hladno / kaldt / студено / i fhohtë / بارد

warm / chaud / hot / caldo / caliente / warm / varmt / quente / ciepła / teplá / teplá / 热 / горячая / meleg / lämmin / varmt / karštas / Vruća voda / sıcak / cald / ζεστό / toplo / kuum / karsts / topla / varm / тепло / i ngrohtë / ساخن

	leichter	lättare		schwerer	tyngre
	plus facile	lengviau		mais difícil	sunkiau
	easier	lakše		harder	Teže
	plus facile	daha hafif		plus difficile	ağır
	más ligero	mai ușor		más pasedo	mai greu
	lichter	ευκολότερα		zwaarder	βαρύτερα
	lettere	lažje		tyngre	težje
	più allentato	kergem		più serrato	raskem
	stabiej	viegļāks		mocniej	smagāks
	snazši	lakši		obtěžnějši	teže
l'ahšie	lettere	f'azšie	tyngre		
更加简单	лек	更坚固	по-трудно		
лече	mē i lehtë	стабильнее	mē e rēndē		
könnyebb	أسهل	nehezebb	أصلب		
helpommin		vaikeampi			



[www.hansgrohe.com/
cleaning-recommendation](http://www.hansgrohe.com/cleaning-recommendation)

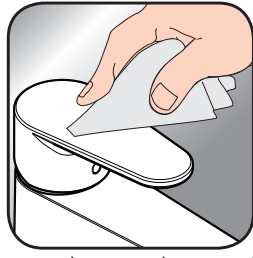

[www.hansgrohe.com/
cleaning-recommendation](http://www.hansgrohe.com/cleaning-recommendation)



[www.hansgrohe.com/
cleaning-recommendation](http://www.hansgrohe.com/cleaning-recommendation)



[www.hansgrohe.com/
cleaning-recommendation](http://www.hansgrohe.com/cleaning-recommendation)

- DE** Reinigungsempfehlung / Garantie / Kontakt
FR Recommandation pour le nettoyage / Garanties / Contact
EN Cleaning recommendation / Warranty / Contact
IT Raccomandazione di pulizia / Garanzia / Contatto
ES Recomendaciones para la limpieza / Garantía / Contacto
NL Aanbevelingen inzake reiniging / Garantie / Contact
DK Rensning, anbefaling / Garanti / Kontakt
PT Recomendações de limpeza / Garantia / Contacto
PL Zalecenie dotyczące pielęgnacji / Gwarancja / Kontakt
CS Doporučení k čištění / Záruka / Kontakt
SK Odporúčania pre čistenie / Záruka / Kontakt
ZH 清洁指南 / 担保 / 接触
RU Рекомендации по очистке / Гарантия / Контакты
HU Tisztítási tanácsok / Garancia / érintkezés
FI Puhdistussuositus / Takuu / Kosketus

- SV** Rengöringsrekommendationer / Garanti / Kontakt
LT Valymo rekomendacijos / Garantija / Kontaktai
HR Preporuke za čišćenje / Garancija / Kontakt
TR Temizleme önerisi / Garanti / Temas
RO Recomandări pentru curățare / Garanție / Contact
EL Σύσταση καθαρισμού / Εγγύηση / επαφή
SL Priporočilo za čiščenje / Garancija / Kontakt
ET Puhastussuovitused / Garantii / Kontakt
LV Tīrīšanas ieteikumi / Garantija / Kontakti
SR Preporuke za čišćenje / Garancija / Kontakt
NO Anbefaling for rengjøring / Garanti / Kontakt
BG Препоръка за почистване / Гаранция / Контакт
SQ Këshilla rreth pastrimit / Garancia / Kontakt
KO 세정시 권장사항 / 품질보증 / 접촉
AR توصيات التنظيف / الضمان (الولايات المتحدة الأمريكية) / اتصال

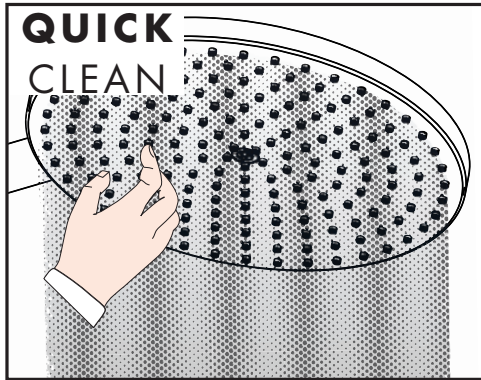

- NL** Eenvoudig schoon: Kalk kan eenvoudig van de noppen worden gewreven.
DK Enkel rengøring: Det er let at fjerne kalkaflejringer fra stråledyserne.
PT Simplesmente limpo: o calcário pode ser simplesmente retirado das saliências através de fricção.
PL Po prostu czysto: Pęczki można całkiem łatwo oczyścić z kamienia.
CS Jednoduše čisté: Vapenné usazeniny můžete z nopenk snadno odstranit otřením.
SK Jednoducho čistý: Vodný kameň sa dá zo štetín celkom ľahko odstrániť.
ZH 清洁: 只需要揉搓花洒表面的出水孔即可去除水垢。
RU Простота чистки: известь очень легко стирается с утолщений.
HU Egyszerűen tiszta: a vízkő egészen könnyen ledörzsölhető a csomókról.
FI Yksinkertaisesti puhdas: kalkin voi helposti hieroa irti nyylistä.
SV Enkelt att göra rent: det är lätt att ta bort kalk från popporna.
LT Paprasta švara: kalkės lengvai nugrandomos nuo kilpos.
HR Jednostavno čisto: Kamenac se sasvim lako uklanja s izbočina.
TR Sadece temiz: Kireç, düğümlemlerle kolayca ovalanabilir.
RO Pur și simplu curat: Calcarul se îndepărtează ușor de pe noduri prin frecare.
EL Απλά τέλεια καθαριότητα: Τα άλατα μπορούν να αφαιρεθούν με μεγάλη ευκολία από τα στόμια.
SL Preprosto čisto: arnenec se z lahkoto podrgne z vozličkov.
ET Lihtsalt puhas: lupja saab nappudelt lihtsalt maha hõõruda.
LV Vienkārša tīrīšana: kaļķis no izvirzījumiem ir viegli norubināms.
SR Jednostavno čisto: Kamenac se sasvim lako skida sa izbočina.
NO Simpelten ren: Ved å gnike er det lett å fjerne kalk fra nuppene.
BG Просто чисто: Варовикът лесно може да се изтръси от удебеленията.
SQ Thjesht dhe pastër. Mbetjet gëlqerore mund të hiqen me fërkim të lehtë.
AR إنه سهل التنظيف، حيث يسقط الجير بسهولة شديدة من الأجزاء الناتئة.

