

DE	Gebrauchsanleitung / Montageanleitung	2
FR	Mode d'emploi / Instructions de montage	3
EN	Instructions for use / assembly instructions	4
IT	Istruzioni per l'uso / Istruzioni per Installazione	5
ES	Modo de empleo / Instrucciones de montaje	6
NL	Gebruiksaanwijzing / Handleiding	7
DK	Brugsanvisning / Monteringsvejledning	8
PT	Instruções para uso / Manual de Instalação	9
PL	Instrukcja obsługi / Instrukcja montażu	10
CS	Návod k použití / Montážní návod	11
SK	Návod na použitie / Montážny návod	12
ZH	用户手册 / 组装说明	13
RU	Руководство пользователя / Инструкция по монтажу	14
FI	Käyttöohje / Asennusohje	15
SV	Bruksanvisning / Monteringsanvisning	16
LT	Vartotojo instrukcija / Montavimo instrukcijos	17
HR	Upute za uporabu / Uputstva za instalaciju	18
TR	Kullanım kılavuzu / Montaj kılavuzu	19
RO	Manual de utilizare / Instrucțiuni de montare	20
EL	Οδηγίες χρήσης / Οδηγία συναρμολόγησης	21
SL	Navodilo za uporabo / Navodila za montažo	22
ET	Kasutusjuhend / Paigaldusjuhend	23
LV	Lietošanas pamācība / Montāžas instrukcija	24
SR	Uputstvo za upotrebu / Uputstvo za montažu	25
NO	Bruksanvisning / Montasjeveiledning	26
BG	Инструкция за употреба / Ръководство за монтаж	27
SQ	Udhëzuesi i përdorimit / Udhëzime rreth montimit	28
AR	دليل الاستخدام / تعليمات التجميع	29
HU	Használati útmutató / Szerelési útmutató	30

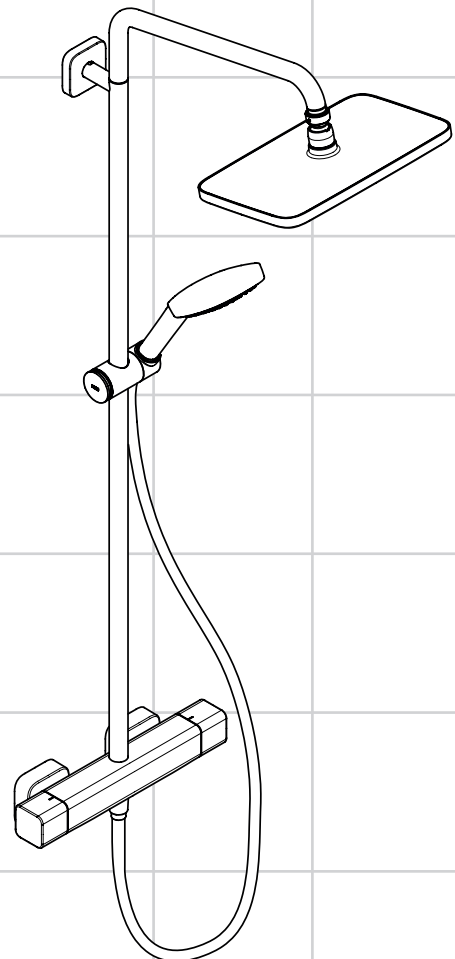

Croma E 280 1jet Showerpipe
27630000



Sikkerhetshenvisninger

- △ Bruk hansker under montasjen for å unngå klem- og kuttskader.
- △ Produktet skal kun brukes for bade-, hygiene- og kroppshygiene.
- △ Armen til hodedusjen er kun laget for å holde hodedusjen. Den må ikke belastes med andre gjenstander!
- △ Barn og voksne med fysiske og psykiske og/eller sensoriske handicap skal ikke bruke dusjsystemet uten oppsyn. Personer som er påvirket av alkohol eller narkotika skal ikke bruke dusjsystemet.
- △ Dusjstrålen skal ikke komme i kontakt med ømfintlige kroppsdeler (f.eks. øynene). Overhold en tilstrekkelig avstand mellom dusjen og kroppen.
- △ Produktet skal ikke brukes som holdegrep. Det skal monteres en separat holdegrep.
- △ Store trykkdifferanser mellom kaldt- og varmtvannstilkoblinger skal utlignes.

Montagehenvisninger

- Før montasjen skal produktet sjekkes for transportskader. Etter monteringen aksepteres ikke noen transport- eller overflateskader.
- Ledningene og armaturen skal monteres, spyles og sjekkes iht. de gyldige normer.
- Gjeldende retningslinjer for rørleggerarbeid i de enkelte land skal følges.
- Monteringsmål i monteringsveiledningen er beregnet for personer som er omtrent 1800 mm høye, målene skal eventuell tilpasses om nødvendig. Her skal man passe på at ved endrede monteringsmålene blir minstehøyden endret, og det må tas hensyn til de endrede tilkoblingsmålene.
- Under monteringen av produktet gjort av kvalifisert fagpersonell, skal man påse at monteringsoverflaten på hele festeområdet er plant (ingen utstikkende fuger eller flisekanter), at veggoppbyggingen egner seg for produktmontasjen og ikke viser svake punkter.
- Den forhåndsmonterte filterinnsatsen skal brukes for å garantere hånddusjens standardgjennomstrømning og for å forhindre smussinnspylinger fra ledningsnettet. Smussinnspylinger kan påvirke funksjonen negativt og/eller føre til skader på hånddusjens funksjonsdeler. Hansgrohe påtar seg inget ansvar for skader som resulteres av dette.
- Produktet er ikke påtenkt for bruk sammen med et dampbad!
- I en nødsituasjon kan røret kortes ned i området nedenfor, mellom armaturen og hodedusjen ved hjelp av en fin sag.
- Når det oppstår problemer med gjennomstrømningsvannvarmer eller ved store trykkdifferanser skal det monteres en drossel i kaldvannforsyningen. Denne kan leveres som ekstratstyr (artikkelnummer 97510000).

Tekniske data

Driftstrykk	maks. 1 MPa
Anbefalt driftstrykk:	0,17 - 0,5 MPa
Prøvetrykk	1,6 MPa
	(1 MPa = 10 bar = 147 PSI)
Varmtvannstemperatur	maks. 70 °C
Anbefalt temperatur for varmt vann	65 °C
Tilkoblingsmål:	150±12 mm
Tilkoblinger G 1/2:	kaldt høyre - varm venstre
Termisk desinfisering:	maks. 70 °C / 4 min

- Egensikker mot tilbakeflyt
- Produktet er utelukkende designet for drikkevann!

Symbolbeskrivelse

 Ikke bruk silikon som inneholder eddiksyre!

max. ≈ 42 °C Safety Function (se side 34)

Takket være egenskapen "Safety Function" kan det forhåndsinnstilles en ønsket maks. temperatur, f.eks. 42 °C.

 **Justering** (se side 34)

Etter avsluttet montering skal termostatens utløpstemperatur kontrolleres. Det er nødvendig med korrektur når temperaturen målt ved uttaksstedet avviker fra temperaturen som er innstilt på termostaten.

 **Vedlikehold** (se side 35)

- Funksjonen til returløpssperren skal iht. DIN EN 1717 og i samsvar med de nasjonale og lokale forskrifter sjekkes regelmessig (minst en gang i året).
- For å holde regulerings-enheten bevegelig, skal termostaten stilles fra tid til annen på helt varmt og helt kaldt.

 **Mål** (se side 31)

 **Gjennomstrømningsdiagram** (se side 31)

- ① Hånddusj
- ② Hodedusj

 **Service-deler** (se side 40)

Ekstratilbehør (ikke med i leveransen)

 Utligningsskive for fliser #93527000 (se side 40)

 **Rengjøring** (se side 36)

 **Betjening** (se side 38)

Sett dusjhodet litt på skrå for å tømme det etter bruk.

 **Prøvemerket** (se side 40)

Feil	Årsak	Feilrettelse
Lite vann	- Forsyningstrykk er ikke tilstrekkelig	- Ledningstrykk sjekkes
	- Smussfangersil til regulerings-enheten skitten.	- Smussfangersil før termostaten og på regulerings-enheten rengjøres
	- Dusjens filterinnsats er skitten	- rengjøring filterinnsats mellom dusj og slangen
Krysstrømning, varmt vann presses ved lukket armatur inn i kaldvannsledning eller omvendt	- Returløpstopper skitten / defekt	- Returløpstopper rengjøres, byttes hvis nødvendig
Utløpstemperatur samsvarer ikke med innstilt temperatur	- Termostat ble ikke justert	- Termostat justeres
	- For lav varmtvannstemperatur	- Varmtvannstemperatur økes til mellom 42 °C og 65 °C
Temperaturregulering er ikke mulig	- regulerings-enhet forkalket	- regulerings-enhet byttes
gjennomstrømningsvannvarmer innkobler ikke under termostatdrift	- Smussfangersil skitten	- Smussfangersil rengjøres / byttes
	- Returløpstopper sitter fast	- Returløpstopper byttes
	- Drossel til hånddusjen ikke fjernet	- Drossel fjernes fra hånddusjen

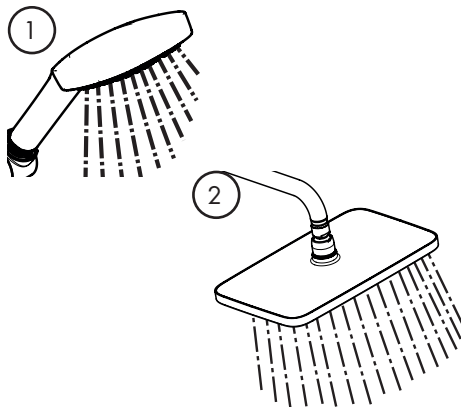
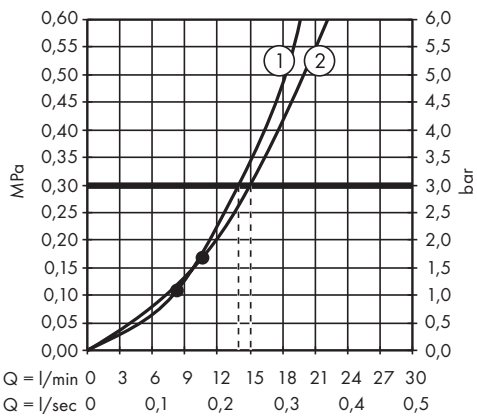
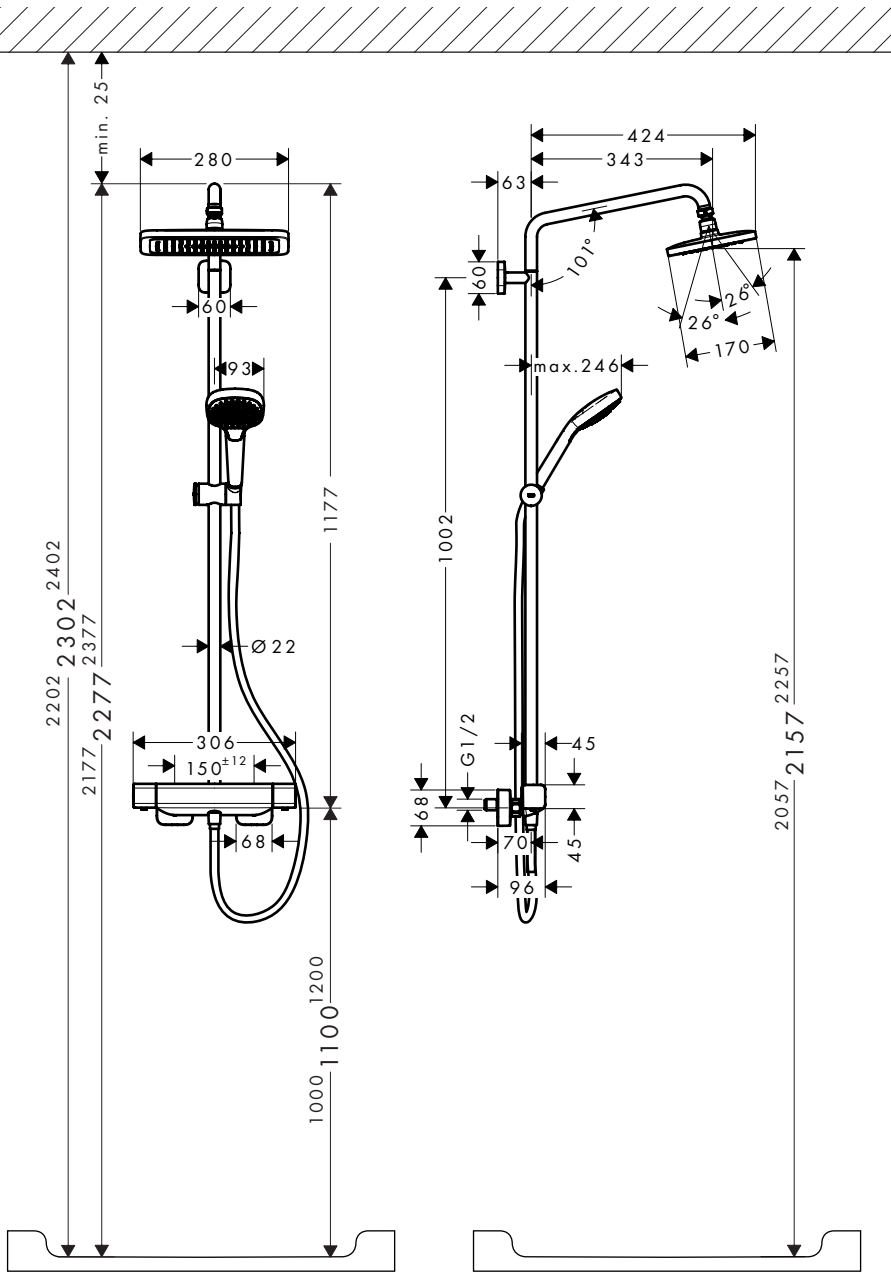

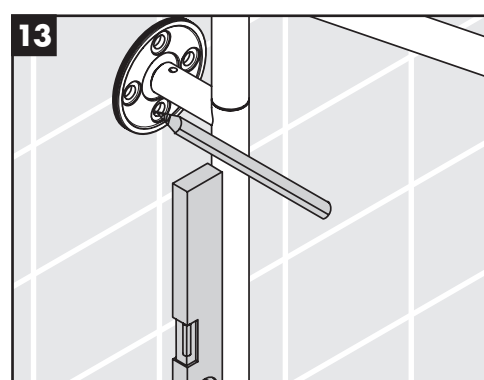
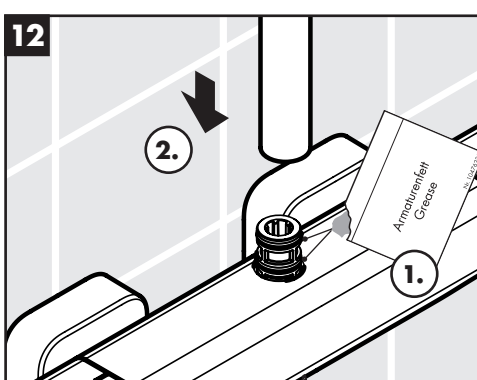
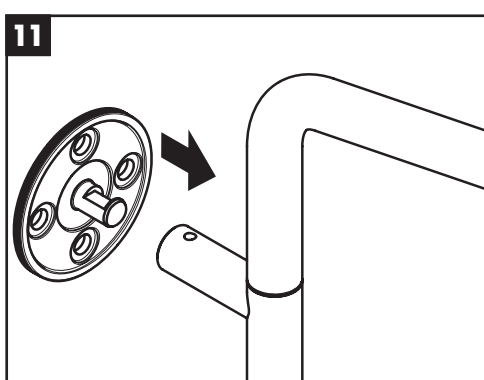
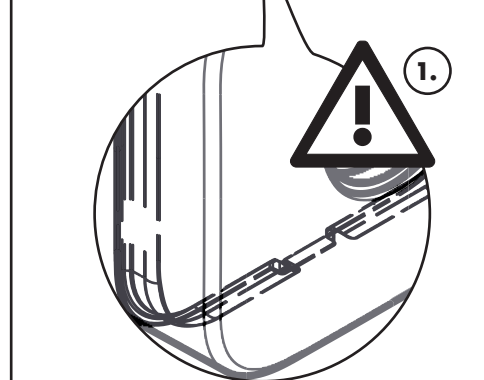
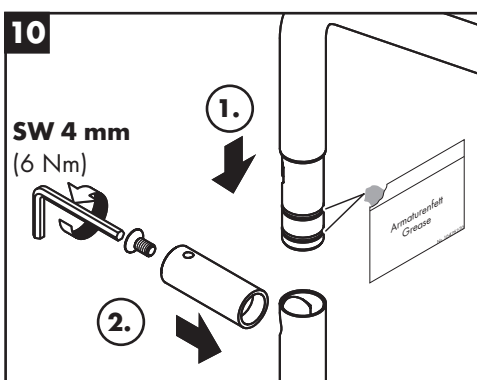
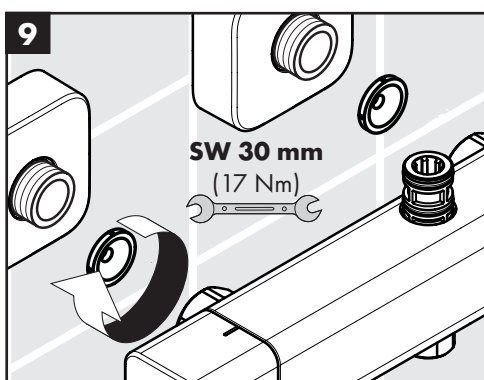
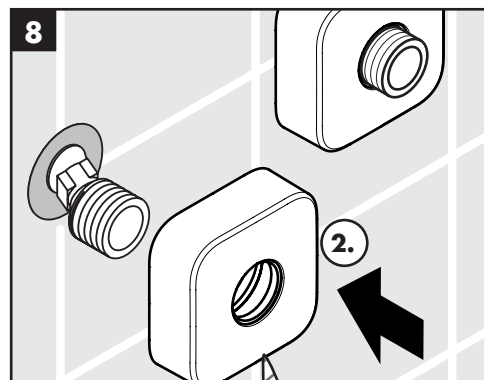
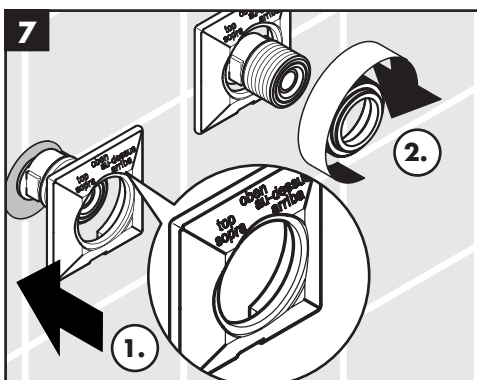
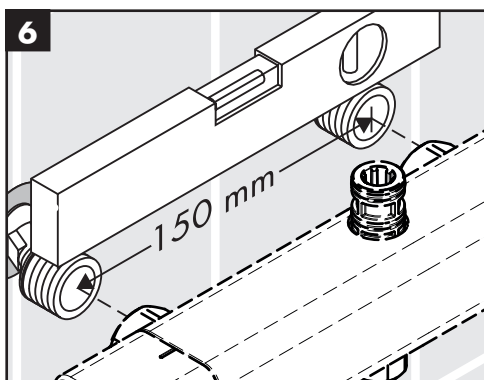
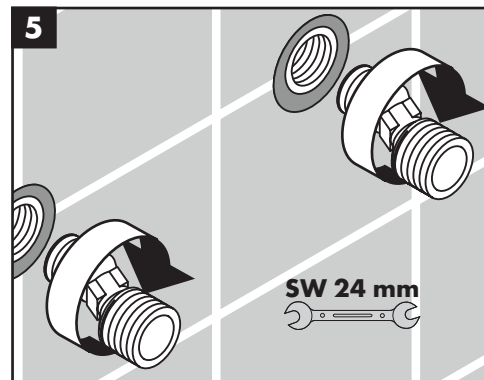
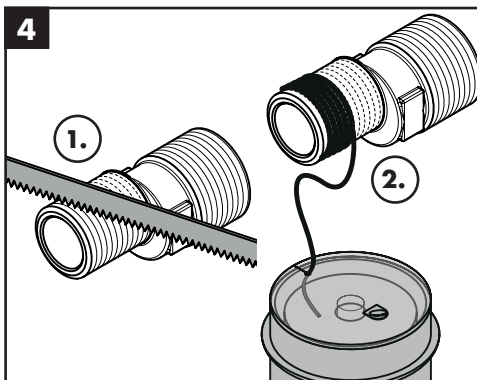
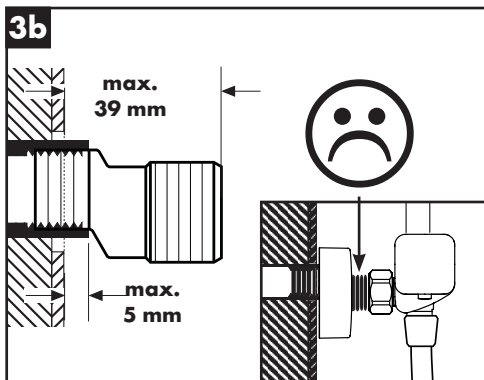
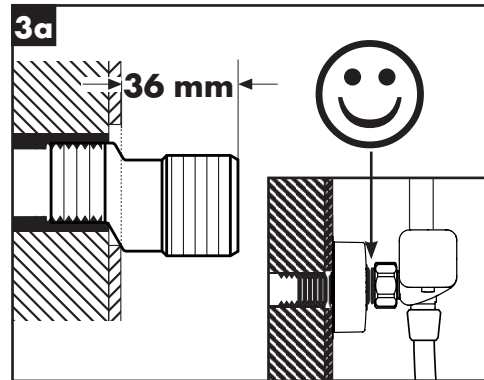
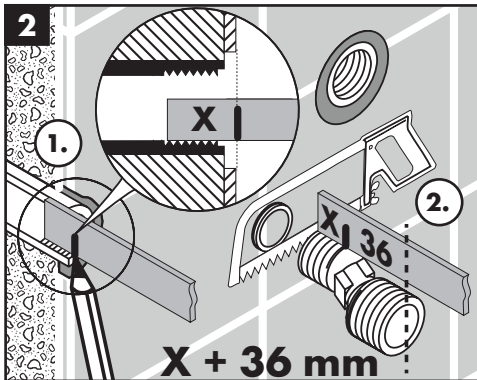
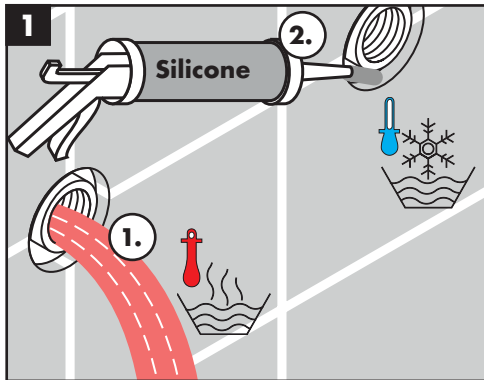

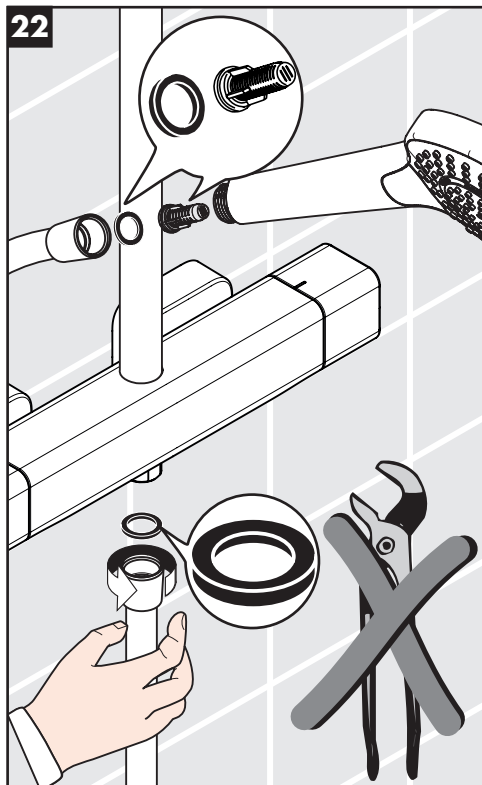
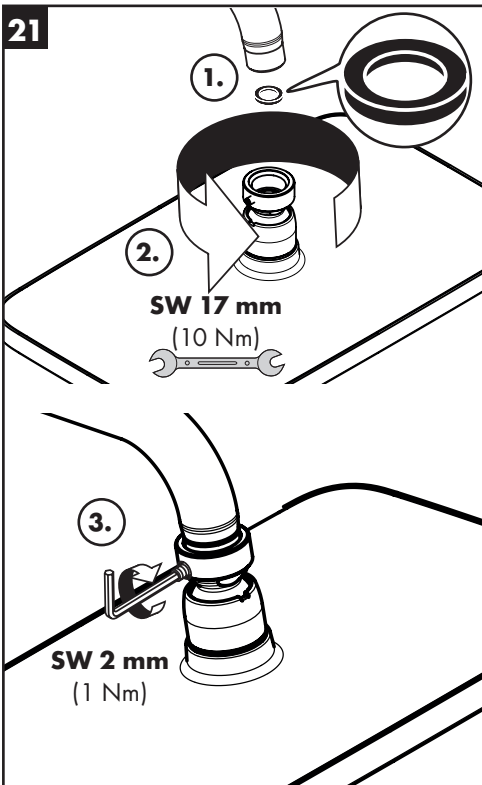
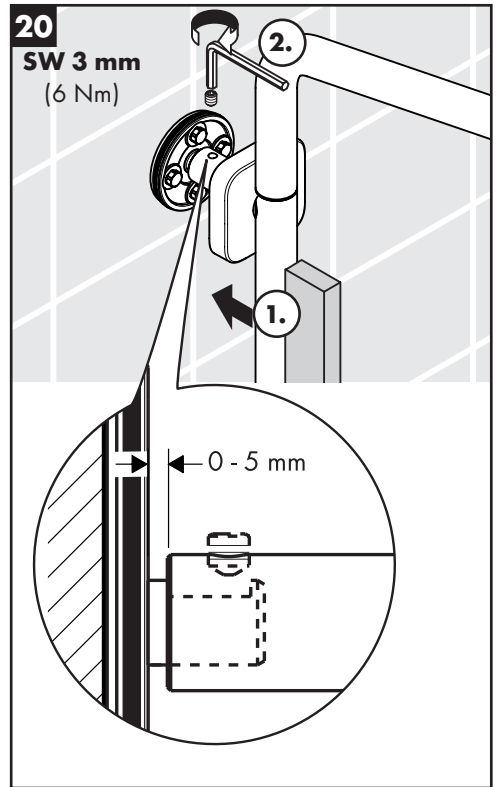
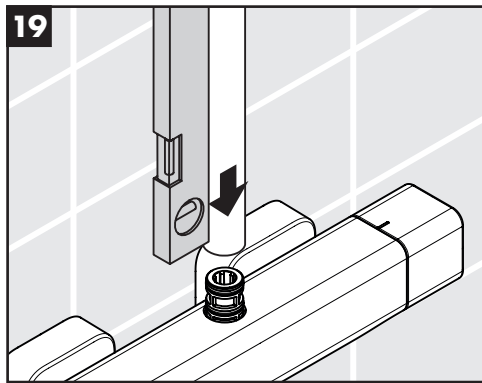
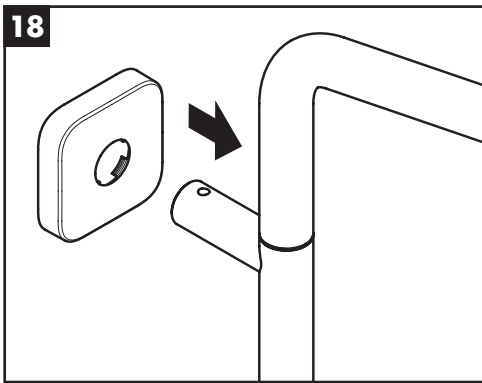
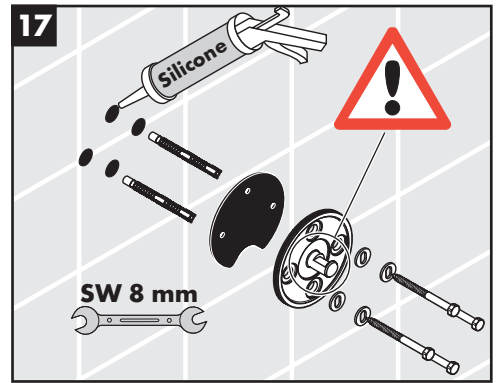
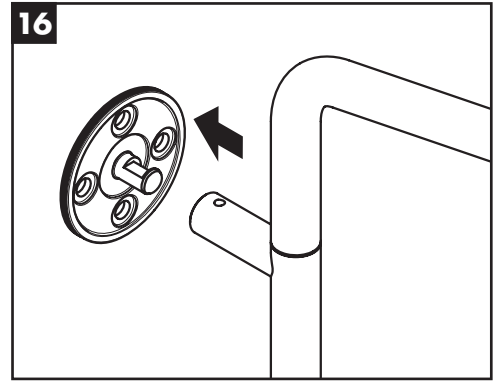
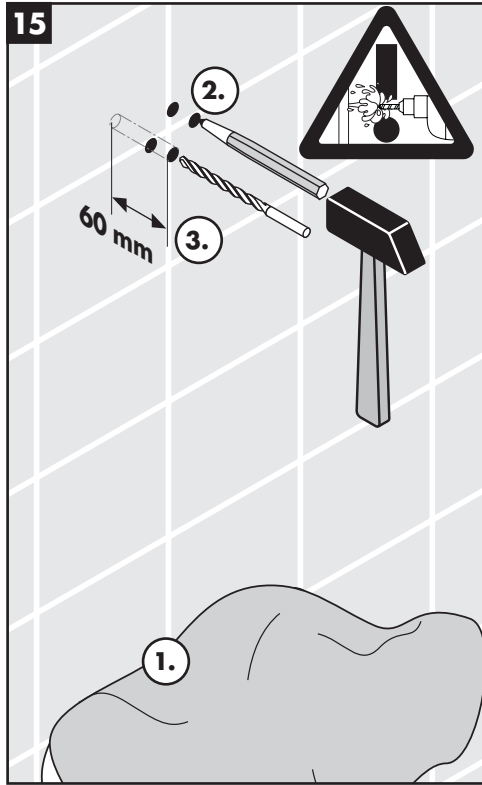
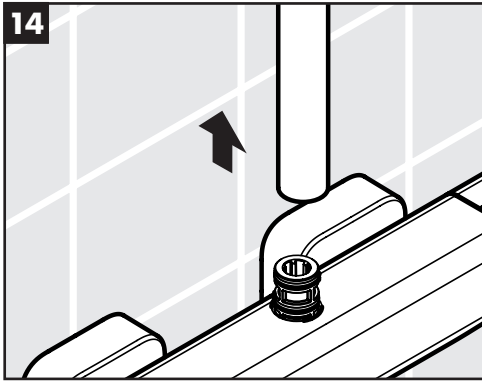

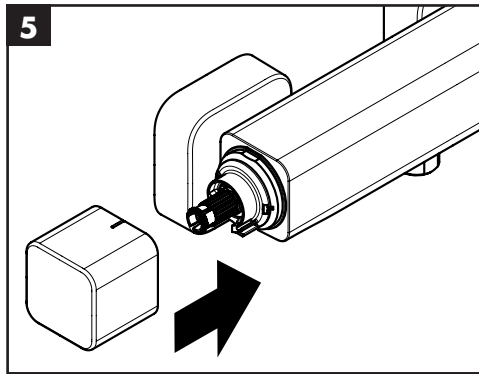
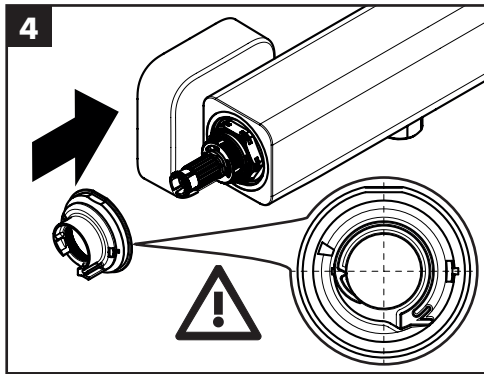
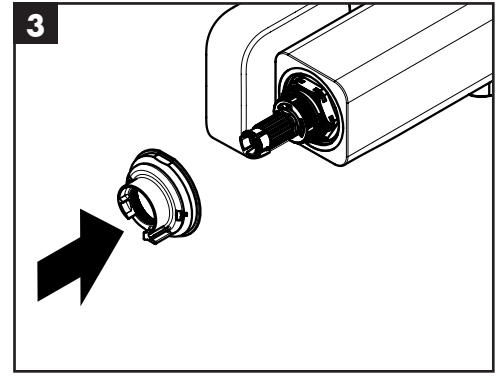
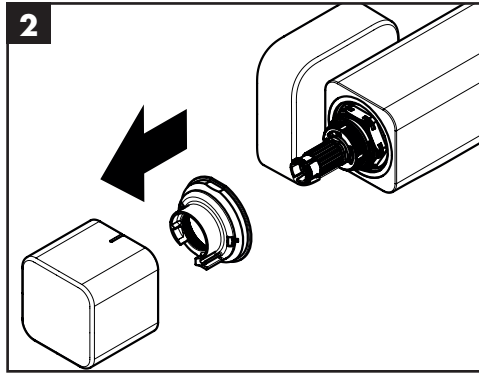
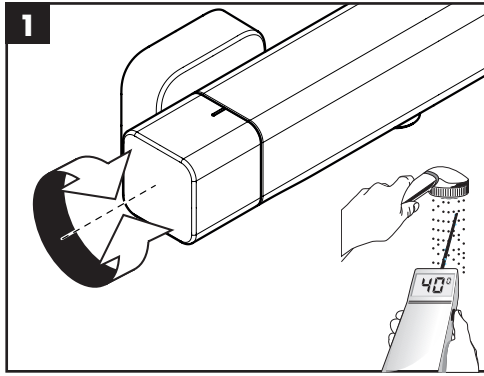

max.
≈ 42° C

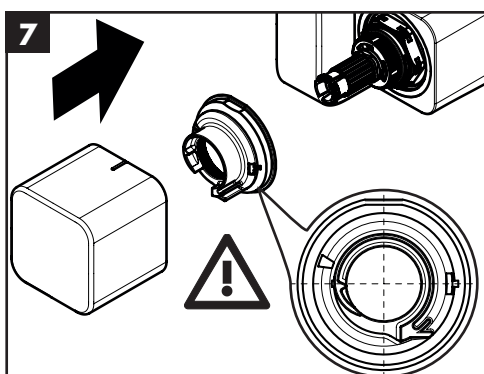
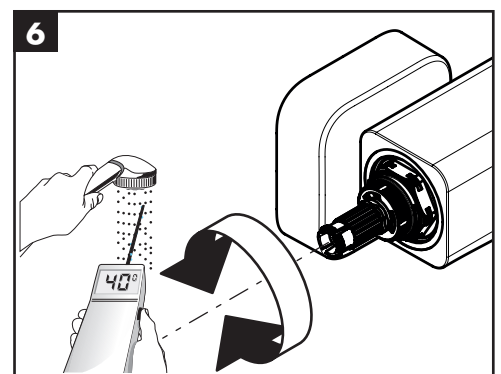
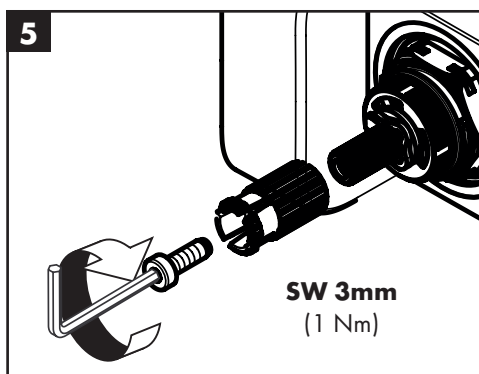
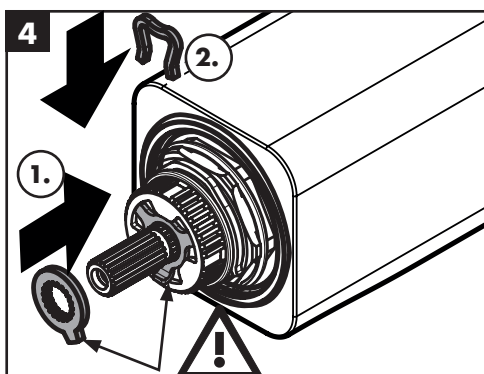
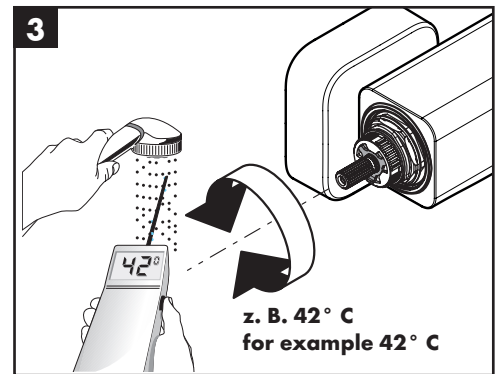
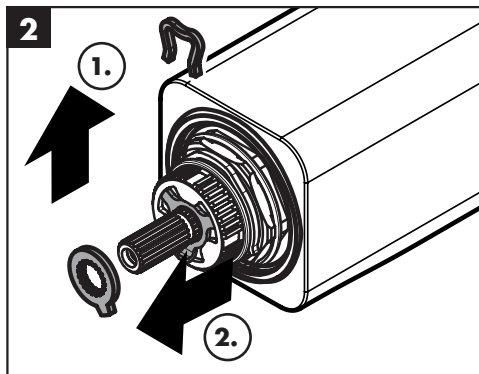
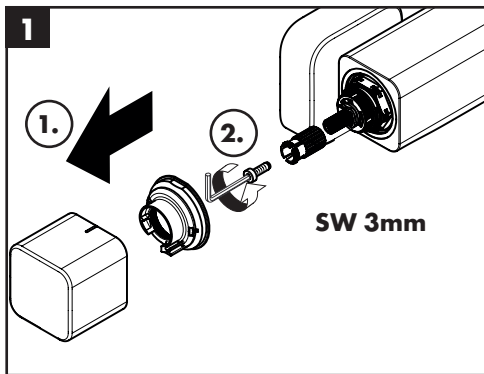

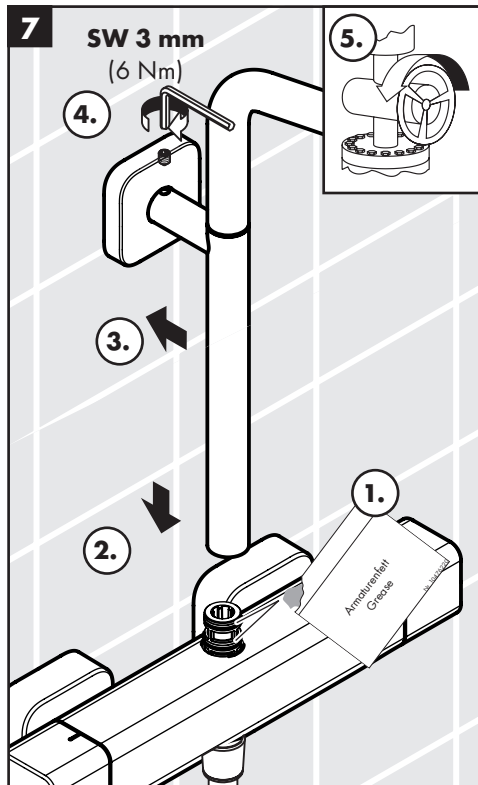
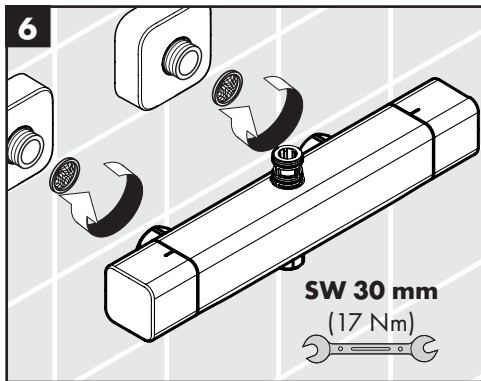
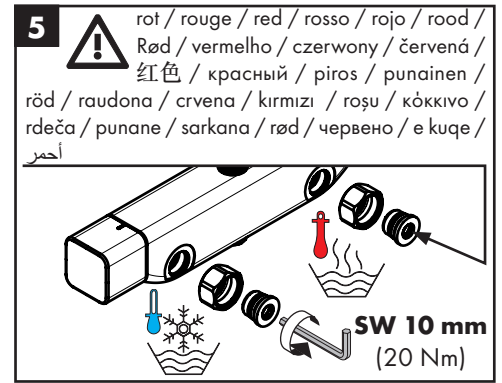
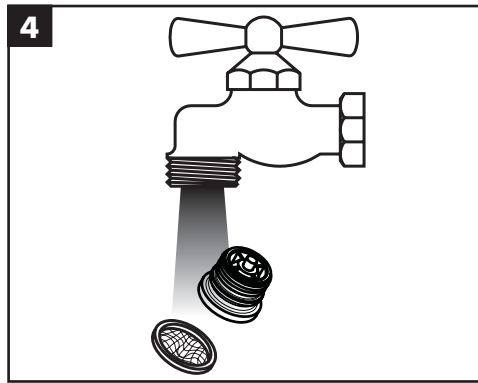
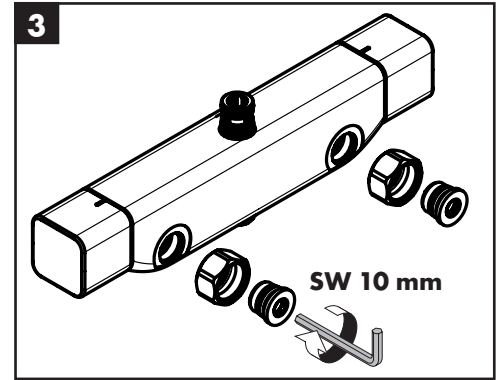
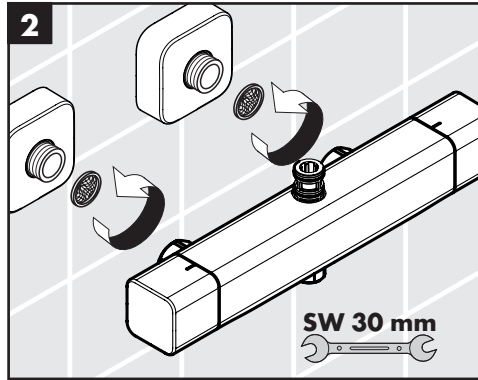
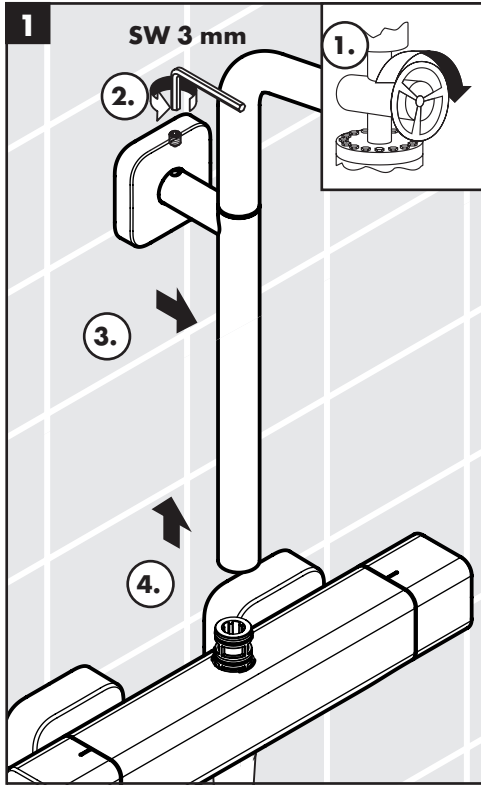



[www.hansgrohe.com/
cleaning-recommendation](http://www.hansgrohe.com/cleaning-recommendation)

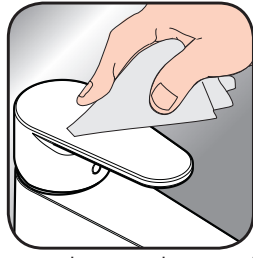

[www.hansgrohe.com/
cleaning-recommendation](http://www.hansgrohe.com/cleaning-recommendation)



[www.hansgrohe.com/
cleaning-recommendation](http://www.hansgrohe.com/cleaning-recommendation)



[www.hansgrohe.com/
cleaning-recommendation](http://www.hansgrohe.com/cleaning-recommendation)

DE Reinigungsempfehlung / Garantie / Kontakt

FR Recommandation pour le nettoyage / Garanties / Contact

EN Cleaning recommendation / Warranty / Contact

IT Raccomandazione di pulizia / Garanzia / Contatto

ES Recomendaciones para la limpieza / Garantía / Contacto

NL Aanbevelingen inzake reiniging / Garantie / Contact

DK Rensning, anbefaling / Garanti / Kontakt

PT Recomendações de limpeza / Garantia / Contacto

PL Zalecenie dotyczące pielęgnacji / Gwarancja / Kontakt

CS Doporučení k čistění / Záruka / Kontakt

SK Odporúčania pre čistenie / Záruka / Kontakt

ZH 清洁指南 / 担保 / 接触

RU Рекомендации по очистке / Гарантия / Контакты

HU Tisztítási tanácsok / Garancia / érintkezés

FI Puhdistussuositus / Takuu / Kosketus

SV Rengöringsrekommendationer / Garanti / Kontakt

LT Valymo rekomendacijos / Garantija / Kontaktai

HR Preporuke za čišćenje / Garancija / Kontakt

TR Temizleme önerisi / Garanti / Temas

RO Recomandări pentru curățare / Garanție / Contact

EL Σύσταση καθαρισμού / Εγγύηση / επαφή

SL Priporočilo za čiščenje / Garancija / Kontakt

ET Puhastussuovitused / Garantii / Kontakt

LV Tīrīšanas ieteikumi / Garantija / Kontakti

SR Preporuke za čišćenje / Garancija / Kontakt

NO Anbefaling for rengjøring / Garanti / Kontakt

BG Препоръка за почистване / Гаранция / Контакт

SQ Këshilla rreth pastrimit / Garancia / Kontakt

KO 세정시 권장사항 / 품질보증 / 접촉

AR توصيات التنظيف / الضمان (الولايات المتحدة الأمريكية) / اتصال

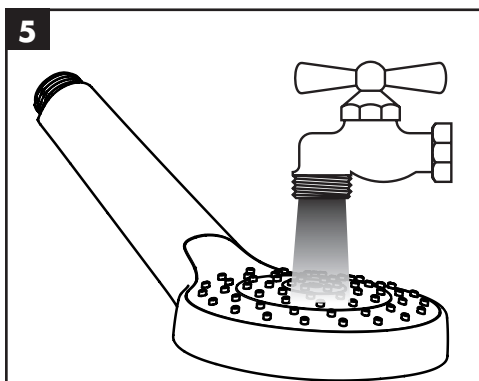
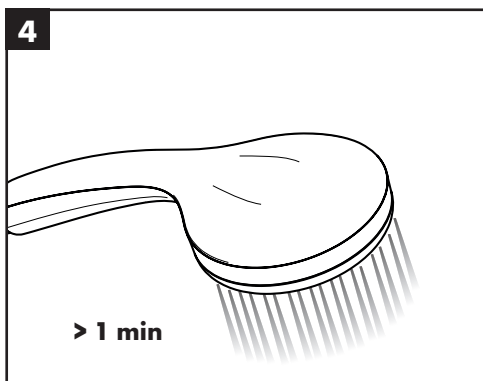
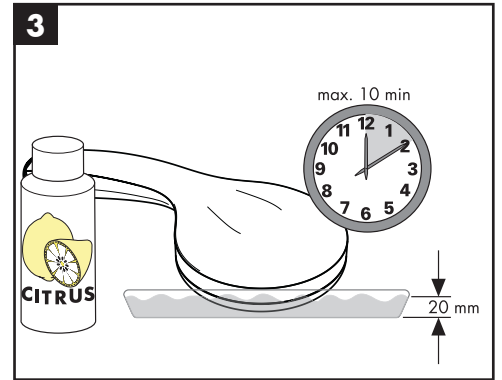
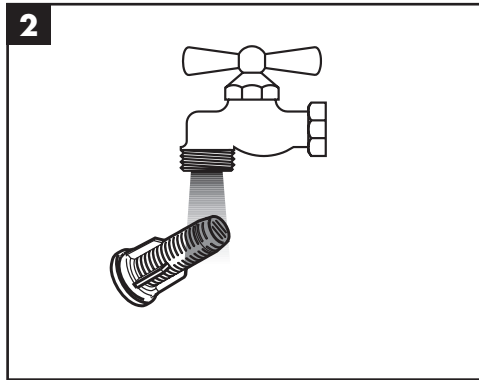
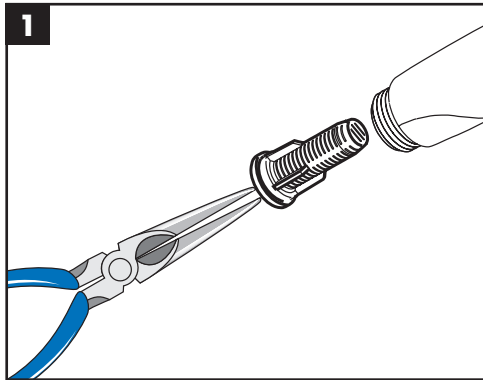

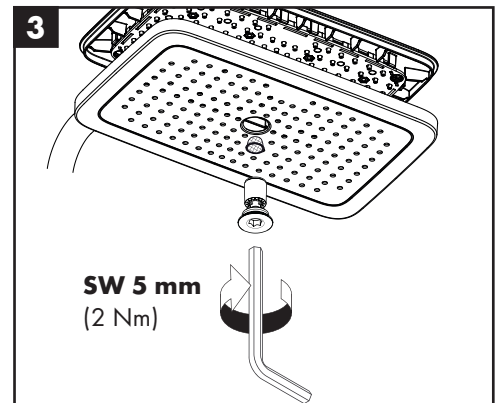
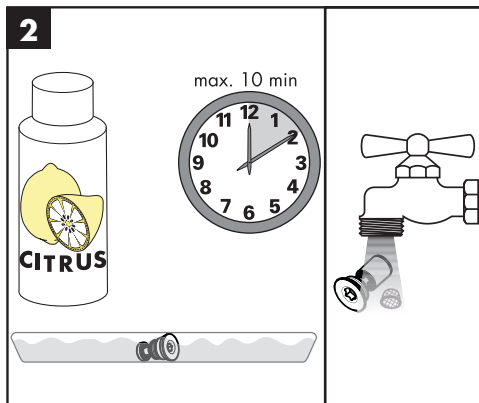
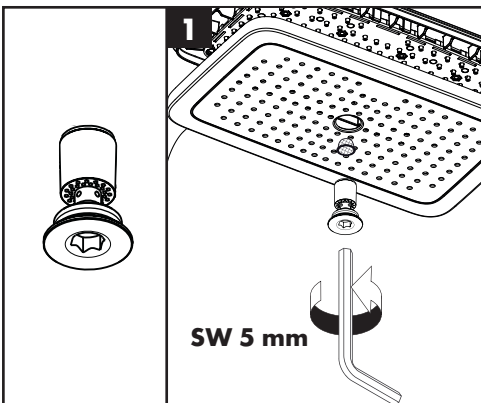
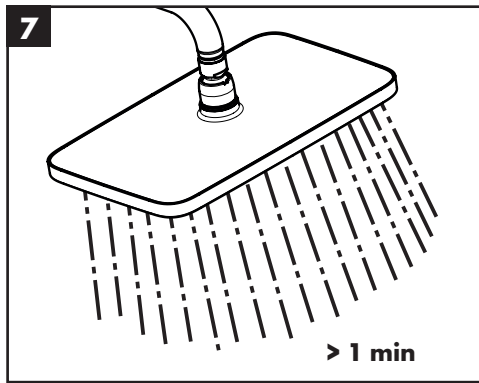
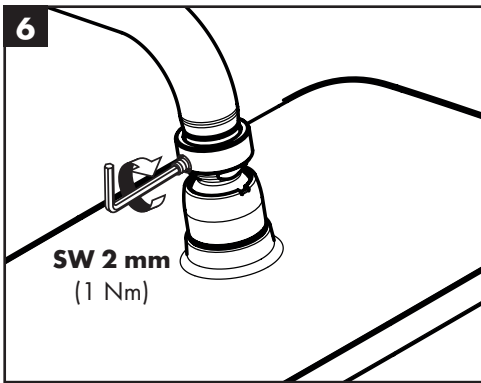
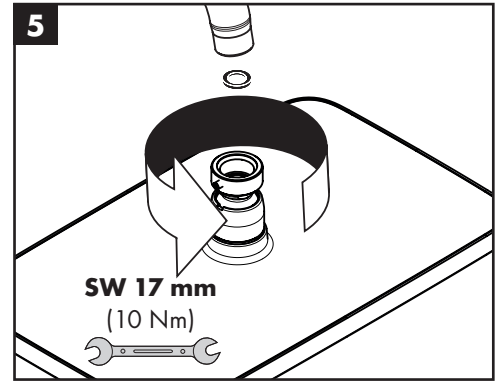
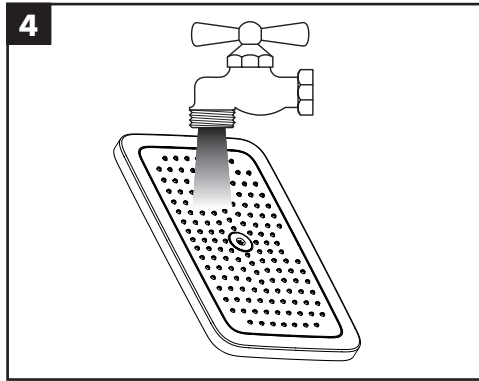
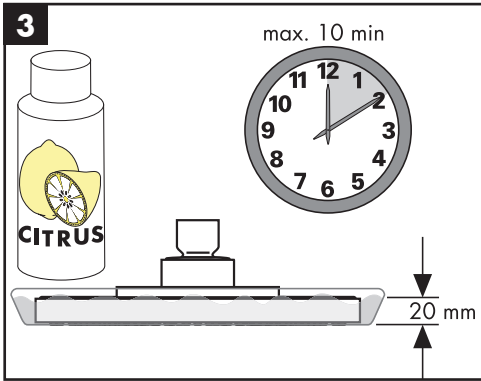
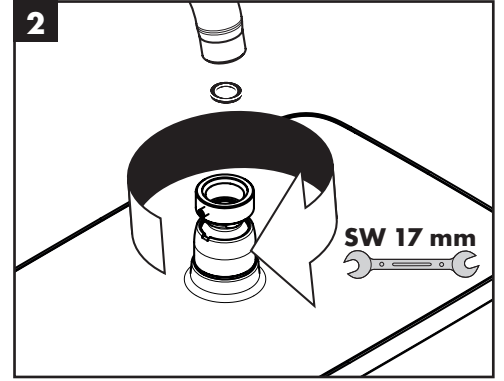
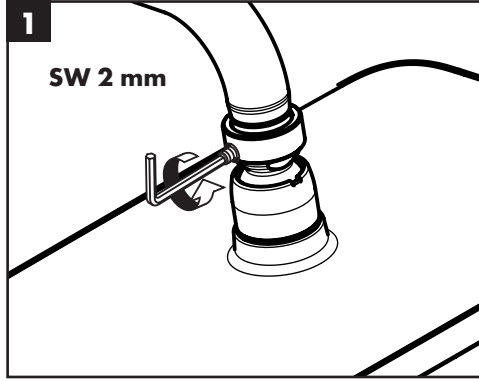
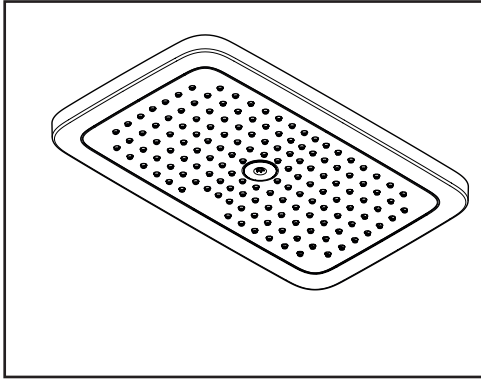

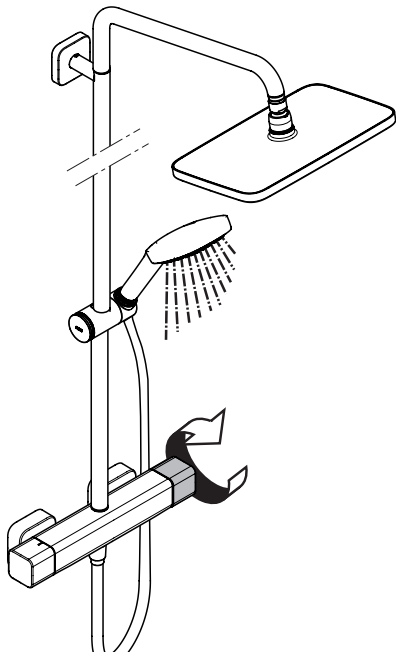

öffnen / ouvert / open / aperto / abierto / open / åbne / abrir / otworzyć / otevřít / otvorit / 开 / открыть / nyitás / avaaminen / öppna / atidaryti / Отваранје / açmak / deschide / ανοικτό / odpreti / avage / atvērt / otvoriti / árpe / отварање / hare / فتح

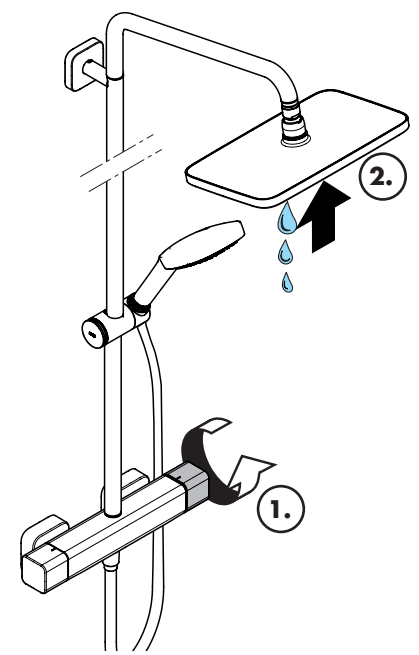
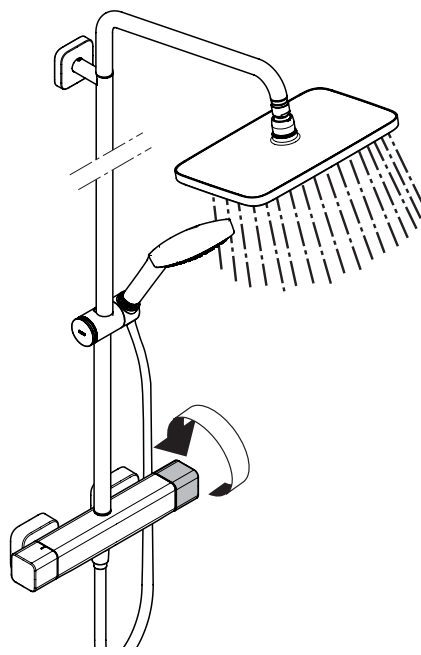

schließen / fermé / close / chiudere / cerrar / sluiten / lukke / fechar / zamknąć / zavřít / uzavrieť / 关 / закрыть / bezárás / sulkeminen / stänga / uždaryti / Zatvaranje / kapatmak / închide / κλειστό / zapreti / sulgege / aizvērt / zatvori / lukke / затваряне / mbylle / إغلاق

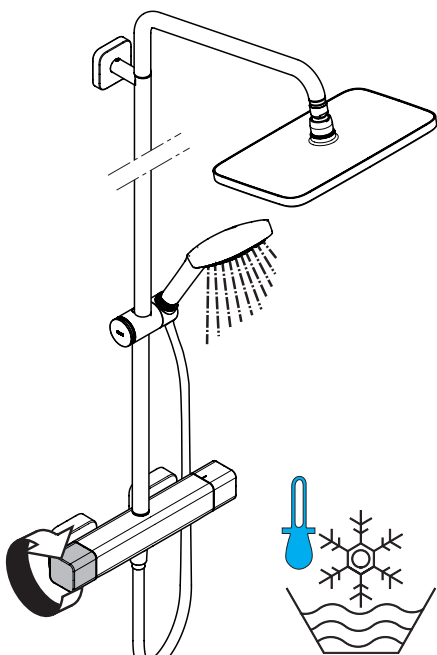

kalt / froid / cold / freddo / frío / koud / koldt / fría / zimna / studená / studená / 冷 / холодная / hideg / kylmä / kallt / šaltas / Hladno / soğuk / rece / κρύο / mrzlo / külm / auksts / hladno / kaldt / студено / i ftohtë / بارد

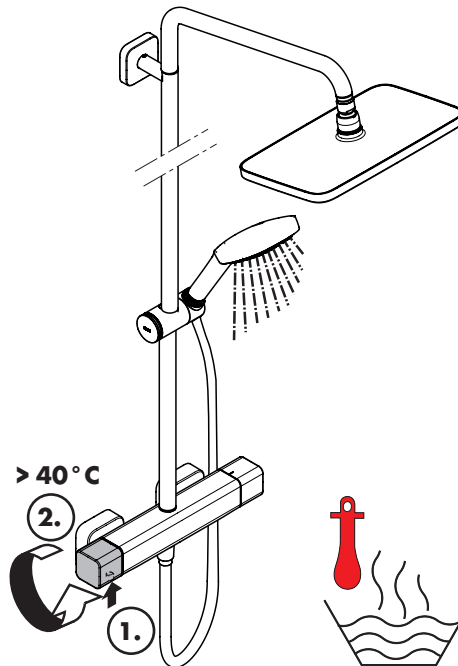

warm / chaud / hot / caldo / caliente / warm / varmt / quente / ciepła / teplá / teplá / 热 / горячая / meleg / lämmin / varmt / karštas / Vruća voda / sıcak / cald / ζεστό / toplo / kuum / karsts / topla / varm / toplo / i ngrohtë / ساخن

Croma Select E Multi 26810400

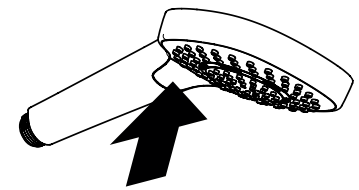

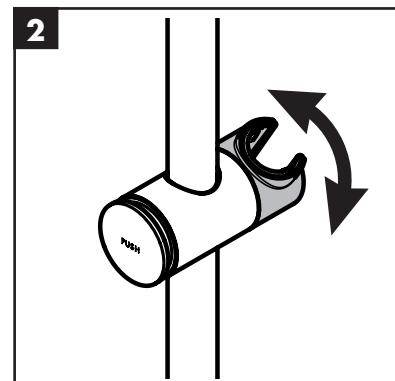
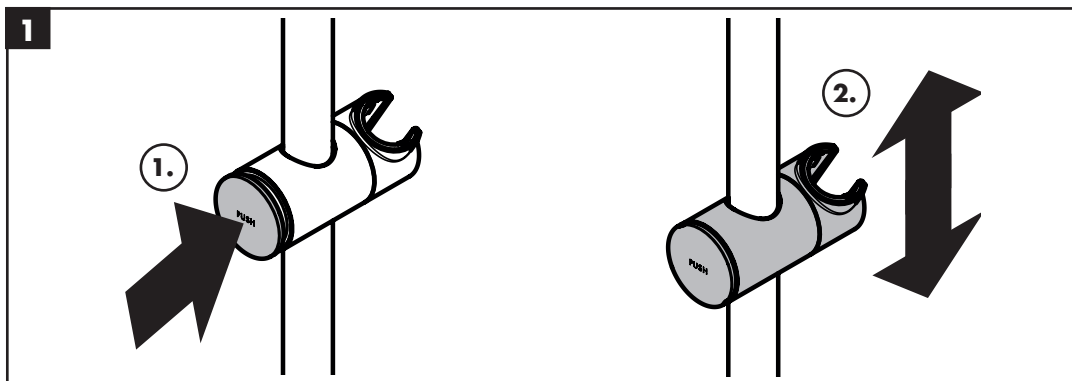

leichter	l'ahšie	lažje
plus facile	更加简单	kergem
easier	Легче	vieglāks
più facile	helpommin	lakši
más ligero	lāttare	lettere
lichter	lengviau	лек
lettere	lakše	mē i lehtë
piú allentato	daha hafif	أسهل
słabiej	mai ușor	könnyebb
snazší	ευκολότερα	

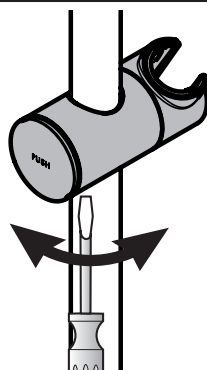

schwerer	t'ažšie	težje
mais difícil	更坚固	raskem
harder	Стабильнее	smagāks
più difficile	vaikeampi	teže
más pasedo	tyngre	tyngre
zwaarder	sunkiau	по-трудно
tyngre	Teže	mē e rēndē
piú serrat	ağır	أصلب
mocniej	mai greu	nehezebb
obtížnější	βαρύτερα	

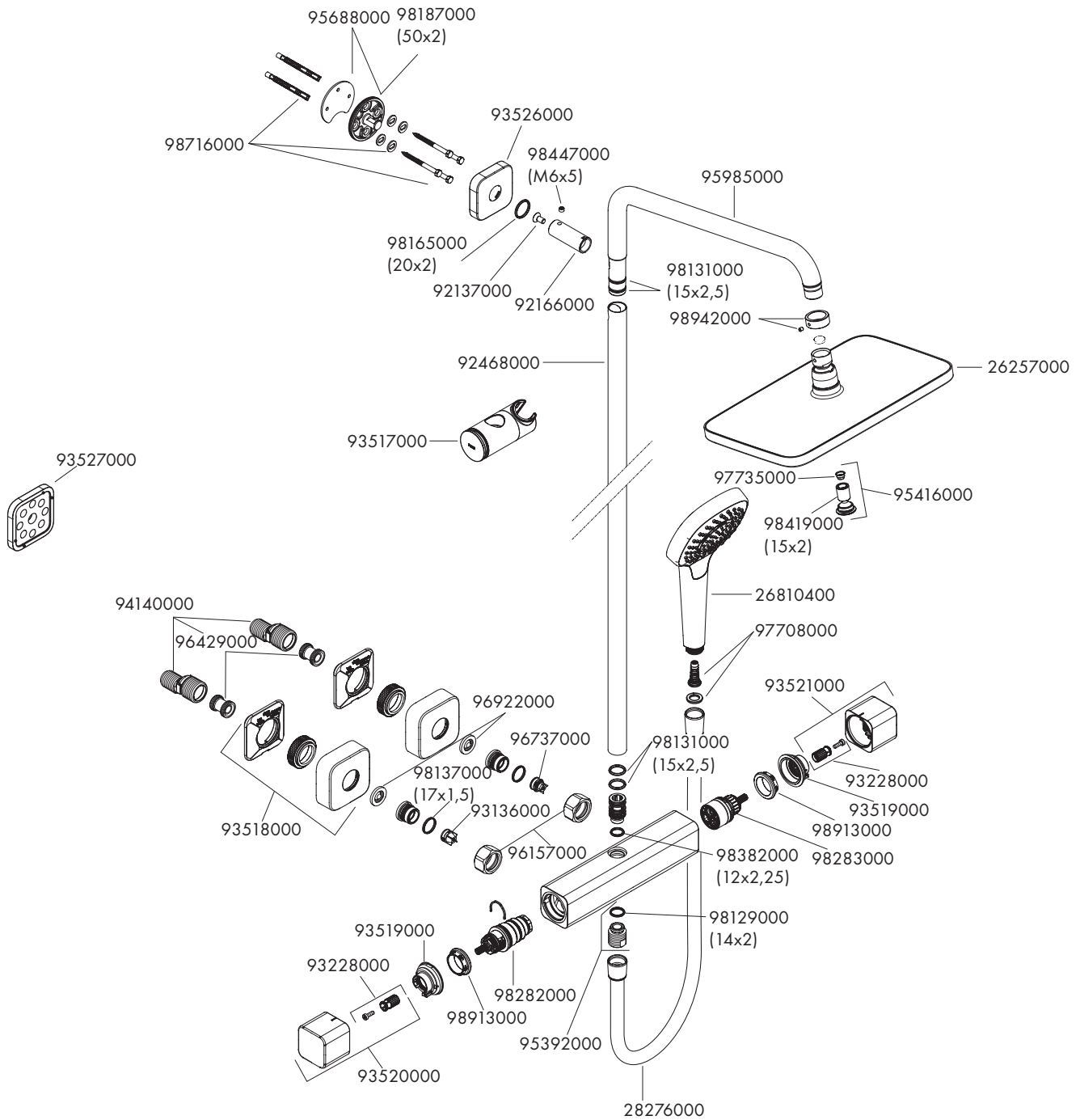

P-IX

DVGW

SVGW



ETA

ACS

27630000

X

hansgrohe

Hansgrohe · Austraße 5 - 9 · D-77761 Schiltach · Telefon +49 (0) 78 36/51-1282 · Telefax +49 (0) 7836/511440
E-Mail: info@hansgrohe.com · Internet: www.hansgrohe.com